

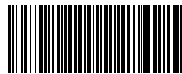

Installation Manual 580/582



www.flightlight.com

Ph: 1.800.806.3548 916.394.2800

2708 47th Avenue, Sacramento

CA 95822





Your Flight Light 580/582 light fixtures have been designed to provide you years of service if you follow the recommendations outlined in this guide. Flight Light recommends that any installation of our heliport or helideck fixtures follow NEC (National Electrical Code) 2014 and any other applicable local electrical codes.

Our fixture is compliant with:

- FAA AC 150/5390-2D Heliport Design Guide
- Exceeds FAA AC 150/5390-2D Appendix G Specifications
- Transport Canada TP14371, AGA 7.16
- IP68 Rating
- Buy American Act Compliant

The **Night Vision Compatibility** feature, allows pilots to see the lights while wearing Night Vision Goggles due to the IR (infrared) LED. The light is compatible with all generation goggles.

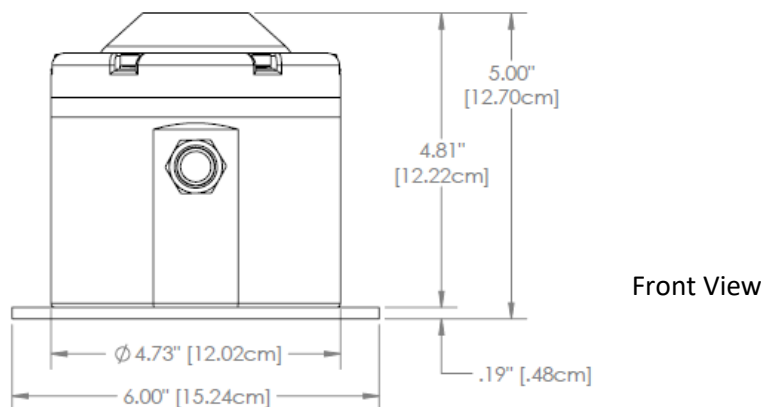
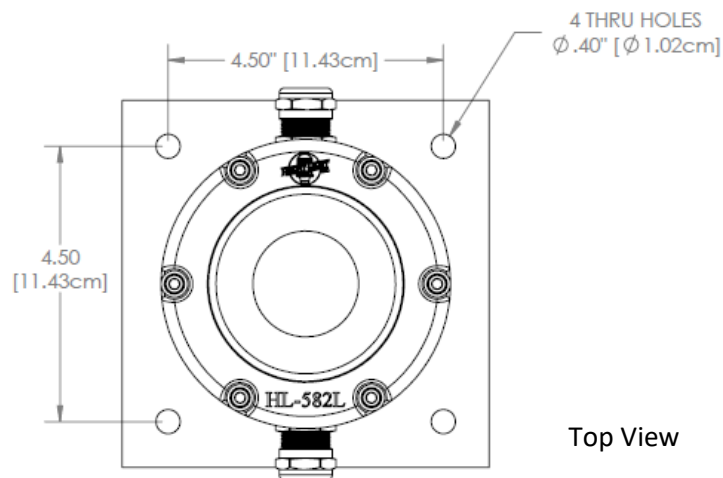





Table of Contents

1. Introduction	1
1.1 About the manual	1
2. Safety Measures	2
3. Assembly Procedures – Required for Lights Supplied Without Cable	3
3.1 Unpacking	3
3.2 Electrical Wiring – AC-Powered, Non-IR Lights, Without Cable	4
3.3 Electrical Wiring – AC-Powered, IR Lights, Without Cable	9
3.4 Wiring Diagrams	13
3.4.1 Wiring Diagram – AC-Powered LED Lights (IR and Non-IR), Single Cable Gland, Supplied with Cable (G1C) (100–240 VAC; AC3 Option: 100–277 VAC)	13
3.4.2 Wiring Diagram – AC-Powered LED Lights (IR and Non-IR), Single Cable Gland with Cable (G1C) (100–240 VAC; AC3 Option: 100–277 VAC)	14
3.4.3 Wiring Diagram – AC-Powered LED Lights (IR and Non-IR), Dual Cable Glands, No Cable (G2NC) (100–240 VAC; AC3 Option: 100–277 VAC)	15
3.4.4 Wiring Diagram – DC-Powered LED Lights, with IR	16
3.4.5 Wiring Diagram – DC-Powered LED Lights, Dimming, with IR	17
3.5 Installation	18
4. Maintenance	18
5. Replacement Parts	19
6. Limited Warranty	20





1. Introduction

The Flight Light model **580** is a **stainless steel fixture** and model **582** is an **anodized Type III aluminum** suitable for a variety of environments. Stainless steel makes it corrosion resistant, increases wear resistance, increases abrasion resistance and flame resistance.

Lights can be purchased

- **with cable** – the lights come all ready assembled and there is no need for additional work on the field
- **without cable** - the lights require field assembling and extended instructions are provided in chapter 3.

Both models are IP68 compliant, water resistant fixture can be submerged in water for several days and still function properly. Impenetrable, factory epoxy potted LED driver and LED board cavity maximizes LED life.

Fully made in the USA, complies with the Buy American Act.

Robust design, user friendly, incorporates the light and the plate in one unit for easy and quick installation in soil, concrete, asphalt, decks or metal platforms. Available in VDC and VAC, the light will ensure proper visual guidance conforming to FAA requirements.

Due to its compact design, can be efficiently used for any temporary application as a portable light.

The installation and maintenance should be done by authorized personnel only.

For questions or guidance during the installation process, please contact our office as engineers and technician are always available to help you.

Phone number: 1-800-806-3458

916-394-2800

OR send an email request to sales@flightlight.com

1.1 About the manual

This manual contains the needed instructions to complete a successful installation. Failure to install the system properly will negatively impact the performance of the system, shorten its life, and may void the manufacturer's warranty.

Not all the items that will be needed to complete the installation are included with the light. The installation procedures section will describe any additional products/tools that may be needed.



2. Safety Measures

You must know whether your heliport lighting system is powered by AC or DC before installing the fixture. AC models work on a range of 100 to 240VAC and for the AC3 model on a range of 100-277VAC. The DC models operate from 10 to 30VDC. The lights are designed to be installed in a parallel circuit, which maintains a constant voltage and brightness for all lights.

Ensure power is off before installing or servicing heliport fixtures!

Follow the local electrical code!

Make sure the equipment is rated and approved for the environment in which you are intending to use it. Do not operate this equipment in humid, flammable, or explosive environments unless it has been rated for safe operation in these environments.

Use only electrical wire of sufficient gauge and insulation to handle the rated current and voltage demand.

Route electrical wiring along a protected path. Make sure they will not be damaged by moving equipment.

Protect components from harsh environment conditions.

Protect equipment with safety devices as specified by applicable safety regulations.

Before starting this equipment, check all safety interlocks, fire –detection systems, and protective devices such as panels and covers. Make sure all devices are fully functional. Do not operate the system if these devices are not working properly.

Never operate equipment with a known malfunction.

Do not attempt to operate or service electrical equipment if standing water is present.

Do not touch exposed electrical connections on equipment while the power is ON!

Wiring and electrical design should be authorized by an electrical contractor.

To provide maximum protection from surges, ensure that the system ground is tested and provides less than 25 ohms to ground resistance.



3. Assembly Procedures — Required for Lights Supplied Without Cable

3.1 Unpacking

Each light is shipped in its own box, together with the needed hardware for assembling.

Carefully remove the light from the packaging and inspect it for any damage. If damage is found, immediately file a claim with the carrier. Also inspect the shipping carton and note any exterior damage that may indicate concealed equipment damage.

Cable is not supplied by Flight Light Inc.

Lights supplied without cable are available in two configurations:

- **Through-Wired Configuration (2 Cords):** Intended for lights installed within a circuit. These units are equipped with two factory-installed cord grips to allow installation of incoming and outgoing power cables.

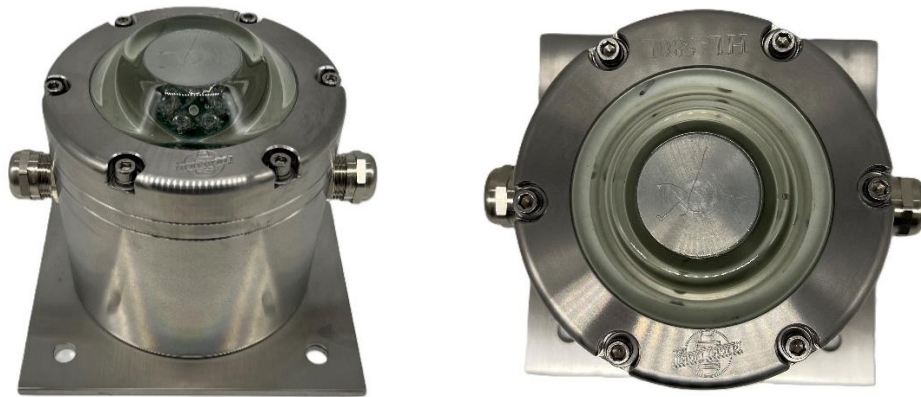

- **End-of-Circuit Configuration (1 Cord):** Intended for the last light in a circuit. These units are equipped with one factory-installed cord grip for the incoming power cable and one factory-installed sealing plug to close the unused cable entry.

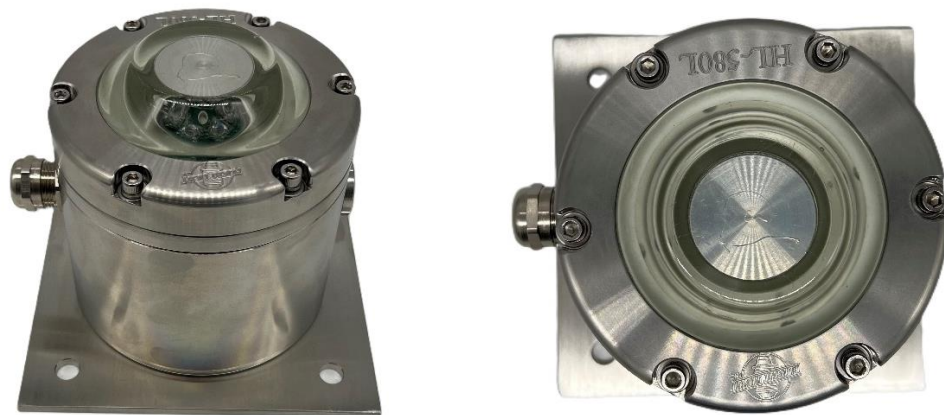



The wire size used for connecting the lighting fixtures must be determined by the project electrical engineer and shall be adequate for the rated voltage and current requirements of the installation.

Cable Minimum Requirements:

- Cable Range O.D. = .24" - .47" (6 - 12 mm)
- Cable individual conductor/wire size: (14-22 AWG)
- Recommended AWG (Varies by application): 16-3/C SOOW 600V 90C
- UL Listed
- Water Resistant

3.2 Electrical Wiring – AC-Powered, Non-IR Lights, Without Cable

The light fixture is secured with six screws.

Remove all six screws using a hand tool only (manual screwdriver). Do not use a power tool or drill driver, as this may damage the fixture. Carefully open the fixture to access the wiring compartment.

Retain all screws for reassembly after wiring is completed.





Refer to the figures below for identification of all wiring leads and their color coding for the Bottom and Top Assemblies.

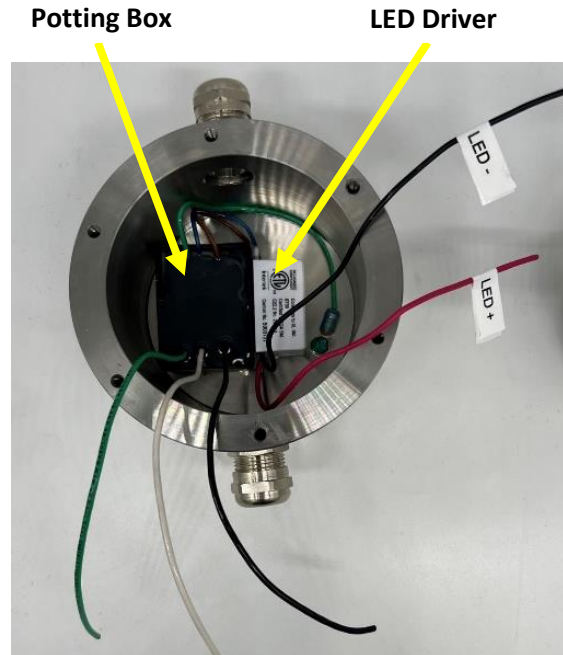

Bottom Assembly

Wires that come from Potting Box:

- Line** (Black Wire)
- Neutral** (White Wire)
- Ground** (Green Wire)

Wires that come from the LED Driver

- Positive** (Red Wire) – labeled “LED +”
- Negative** (Black Wire) – labeled “LED –”

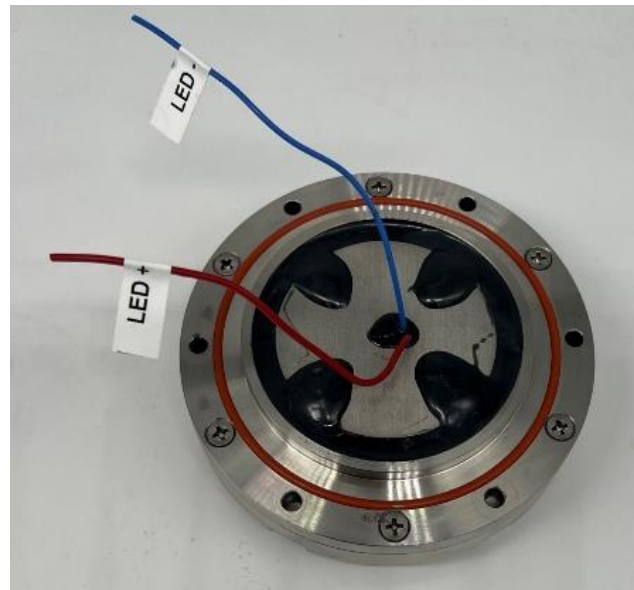

Top Assembly

Wires that come from the Top Assy.

- Positive** (Red Wire) – labeled “LED +”
- Negative** (Blue Wire) – labeled “LED –”

The light is supplied with 5 gel connectors: 3 blue and 2 orange. These connectors are required for initial wiring, with one additional connector of each type provided as spare.





Cable Installation (Bottom Assembly)

The cord grips are pre-installed at the factory and secured with thread locker (Loctite 243). Do not remove the cord grip body from the Bottom Assembly.

1. Prepare the cable

Remove the outer jacket of the incoming cable(s).

Ensure the cable meets the required dimensions:

Cable O.D. range: 0.24" – 0.47" (6 – 12 mm)

Make sure the individual input power conductors meet the following size requirement: AWG 14–22.

IMPORTANT:
Do not strip the wires.

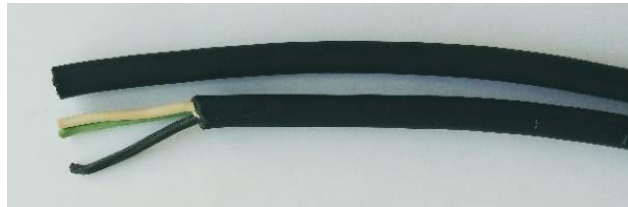

2. Open the cord grip

Loosen only the compression nut of the cord grip. **Do NOT unscrew or remove the cord grip body from the enclosure.**



3. Insert the cable

Pass the prepared cable through the cord grip into the Bottom Assembly.



4. Tighten the cord grip

Re-tighten the compression nut to secure the cable and ensure proper sealing against water ingress.





Now proceed with the wiring connections in the Bottom Subassembly using the blue gel connectors.

Wiring Connections (Bottom Assembly)

Once the cable(s) are installed and secured, proceed with the electrical connections.

The gel connectors are used to connect the wires from the Potting Box (Bottom Assembly) to the wires of the incoming supply cable.

IMPORTANT: Do not strip any wires. All wire connections in this procedure are made using gel connectors and must be installed with the wire insulation intact.

Refer to the table below for correct wire color matching.

Wire Connection Table

Blue Gell Connector / Fixture	No 1: Line (Black Wires)	No 2: Neutral (White Wires)	No 3: Ground (Green Wires)
Two Entries	First cord Line + Second cord Line + Potting Box Line	First cord Neutral + Second cord Neutral + Potting Box Neutral	First cord Ground + Second cord Ground + Potting Box Ground
One Entry	Cord Line + Potting Box Line	Cord Neutral + Potting Box Neutral	Cord Ground + Potting Box Ground

Note: The one-entry (single cord grip) configuration is used for the last fixture in the circuit (end-of-line installation).

Using a suitable tool (e.g., pliers), firmly compress each gel connector. Ensure each connector is fully and securely tightened.

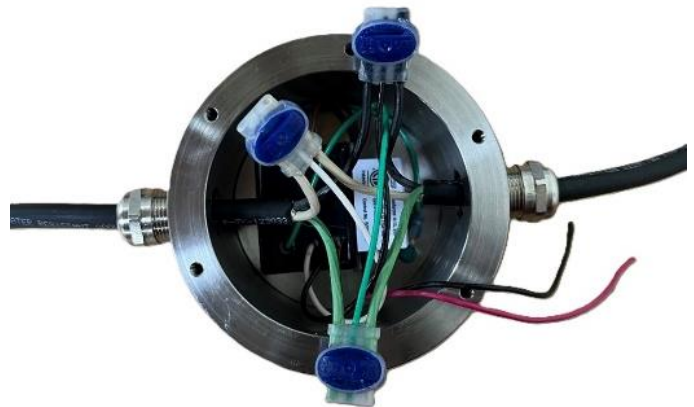



Use the orange gel connectors to connect the LED Driver wires in the Bottom Assembly to the Top Assembly LED board.

Match the wires as follows:

- Positive (Red) → Positive (Red)
- Negative (Blue) → Negative (Black)

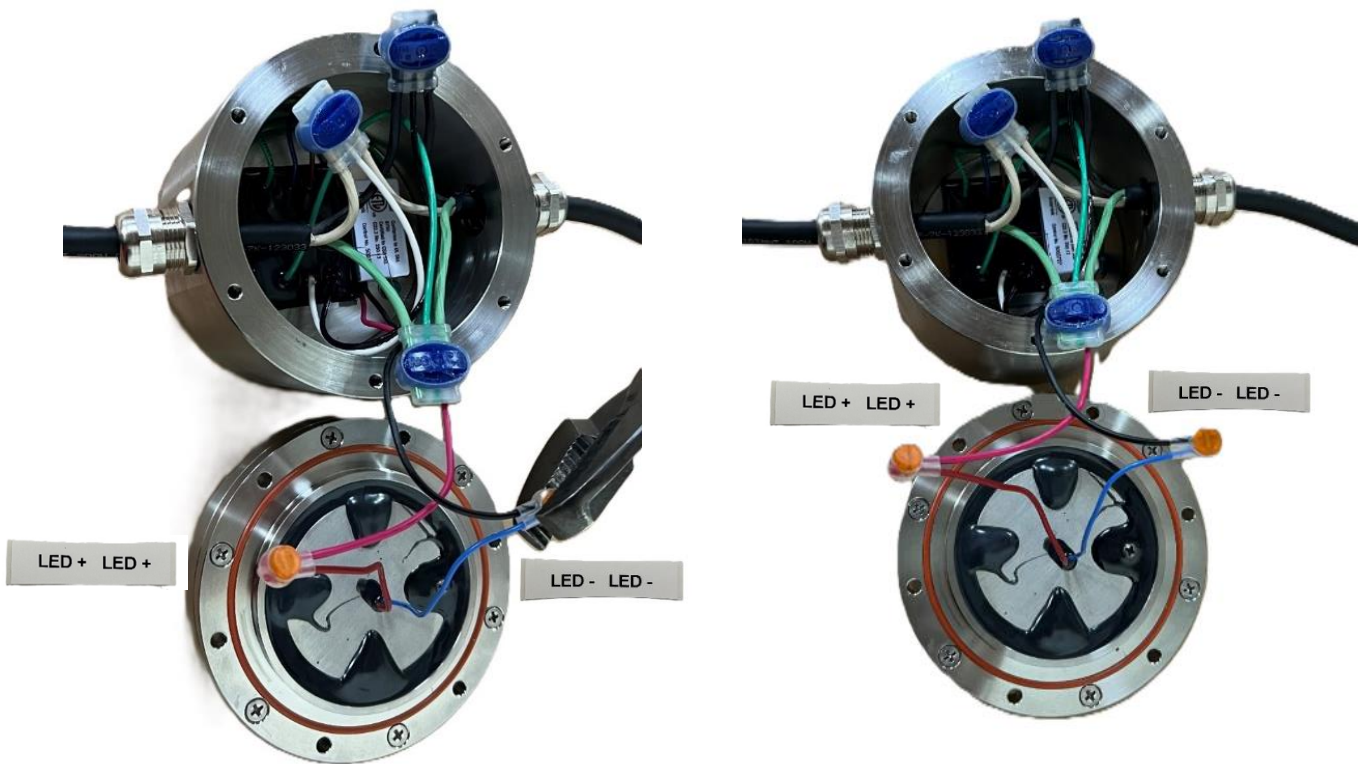

Carefully push all wires and gel connectors to the bottom of the Bottom Assembly, ensuring they are positioned clear of the mating and sealing surfaces.

Carefully place the Top Assembly onto the Bottom Assembly. Ensure that no wires are pinched or trapped between the mating surfaces.

Reinstall and tighten the six screws supplied with the fixture using a hand tool only (manual screwdriver). **Do not use a power tool or drill driver.**



3.3 Electrical Wiring – AC-Powered, IR Lights, Without Cable

The light fixture comes with six head screws securing the assembly.

Remove the screws to open the fixture and prepare it for wiring. Save the screws as they will be needed later for closing the fixture.

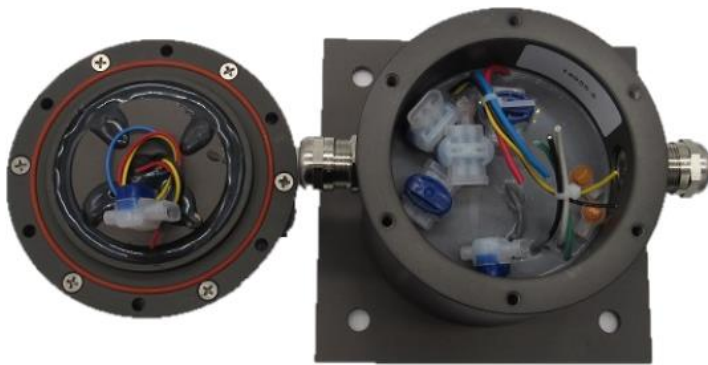

1. Take both incoming cables and remove the external jacket, as shown in picture #14 below. **Make sure your cable meets the following size requirement: Cable Range O.D. .24" - .47" (6 - 12 mm)**
2. Apply loctite over the threads of the cord grips and thread them in the side entries without fully tightening them. Adjust the length of the cables inside the fixture. Make sure the length of the incoming wires matches the length of the wires coming from the bottom of the fixture. Now fully tighten both cord grips using a wrench.



3. Perform a pull test on both cables to make sure they are not loose and you have a secure watertight connection

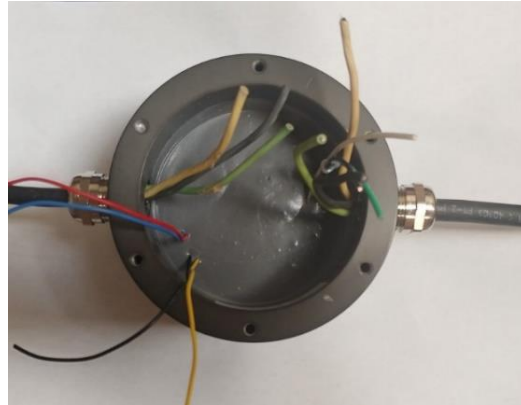

The light comes with:

- Six (6) blue gel (AWG 14-22) connectors: Five (5) needed for initial wiring and one as a spare.
- Three (3) orange gel (AWG 19-22) connectors: Two (2) needed for initial wiring and one as a spare.

AC Input Wiring

1. **DO NOT STRIP THE WIRES!**
2. **Make sure your cable wires meet the following size requirement (AWG 14-22).**
3. Use the three (3) blue gel connectors included with the fixture to make the splicing.
4. Plug all 3 Black (Line) unstripped wires in first blue gel connector, one wire in each position.
5. Plug all 3 White (Neutral) unstripped wires in second blue gel connector, one wire in each position.
6. Plug all 3 Green (Ground) unstripped wires in third blue gel connector, one wire in each position. (See Table 1).

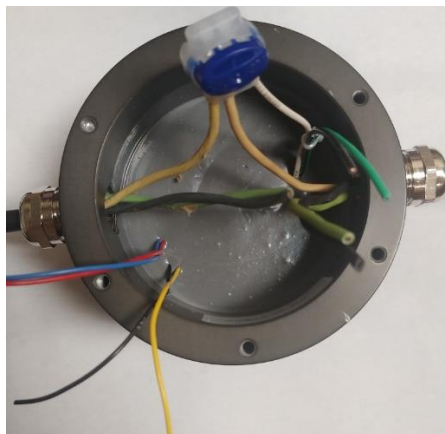



DC LED Wiring

7. DO NOT STRIP THE WIRES!

8. Plug the two Yellow (IR +) unstripped wires in first orange gel connector, one wire in each position.
9. Plug the two Black (IR-) unstripped wires in second orange gel connector, one wire in each position.
10. Plug the two Red (LED +) unstripped wires in fourth blue gel connector, one wire in each position.
11. Plug the two Blue (LED -) unstripped wires in fourth blue gel connector, one wire in each position. (See Table 1).

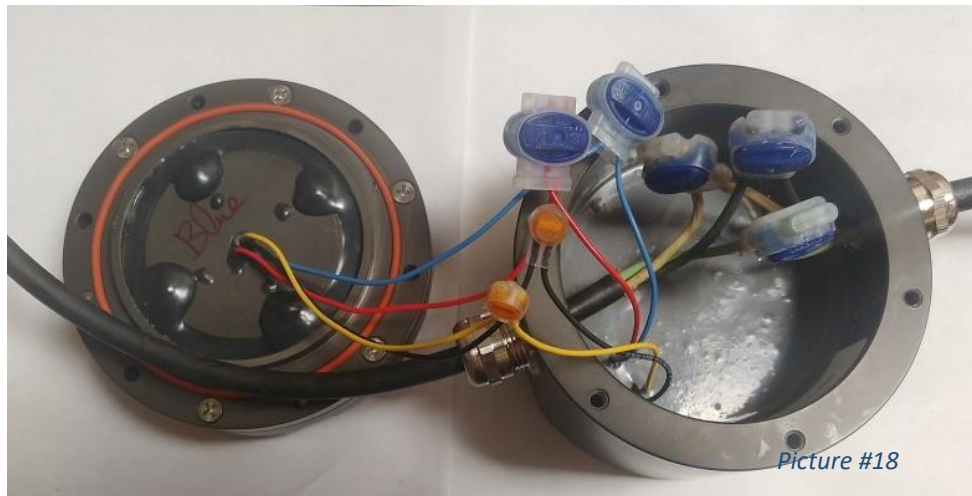

12. Using a wrench squeeze each one of the gel connectors. Please make sure to squeeze tightly.
13. Carefully place the top assembly over the bottom (Please make sure to not pinch any of the wires) and tighten the light using the 6 screws that came with the light.

The electrical wiring of the light is to be done in a parallel circuit with the splice done inside the light fixture. Junction boxes are not provided with the light fixtures.

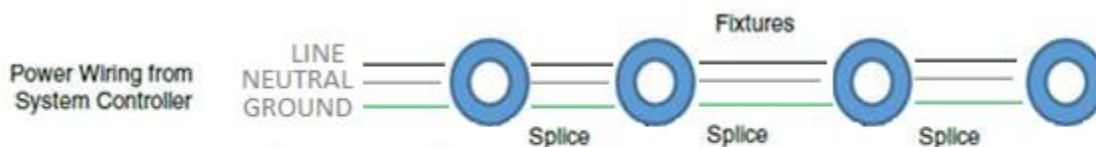

Parallel Connection at Each Fixture



WIRE COLOR	3M GEL CONNECTOR COLOR
BLACK (LINE)	BLUE (14-22 AWG)
WHITE (NEUTRAL)	BLUE (14-22 AWG)
GREEN (GROUND)	BLUE (14-22 AWG)
YELLOW (IR +)	ORANGE (19-26 AWG)
BLACK (IR -)	ORANGE (19-26 AWG)
RED (LED +)	BLUE (14-22 AWG)
BLUE (LED -)	BLUE (14-22 AWG)



3.4 Wiring Diagrams

3.4.1 Wiring Diagram – AC-Powered LED Lights (IR and Non-IR), Single Cable Gland, Supplied with Cable (G1C) (100–240 VAC; AC3 Option: 100–277 VAC)

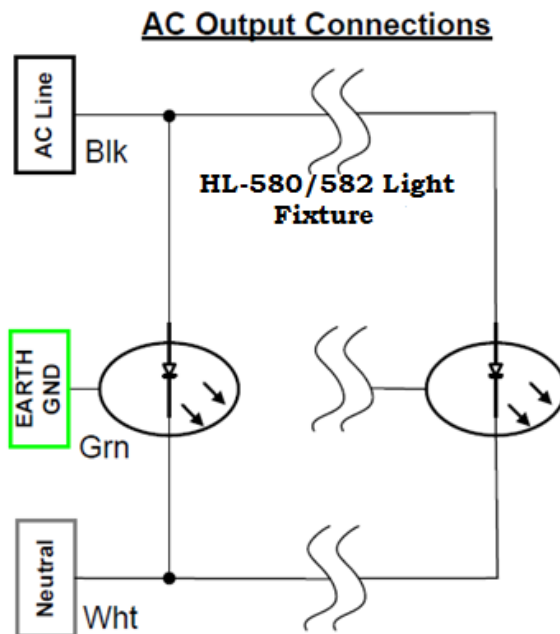
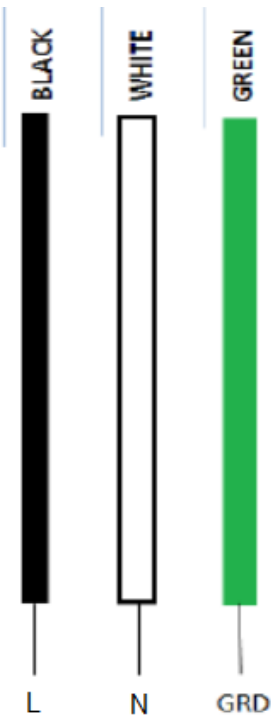
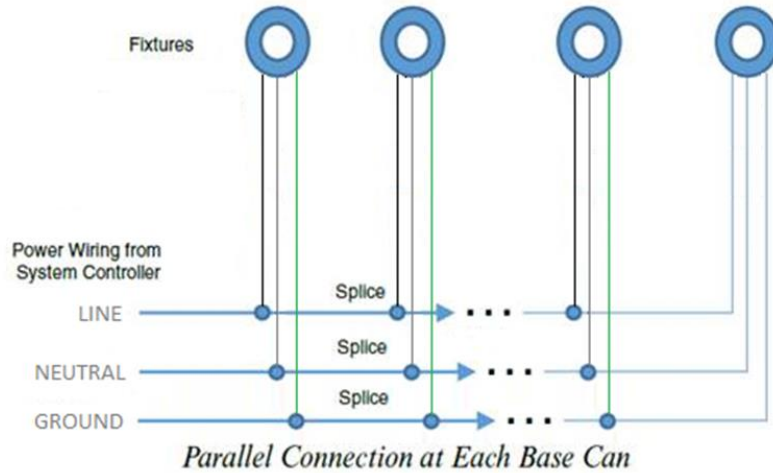



3.4.2 Wiring Diagram – AC-Powered LED Lights (IR and Non-IR), Single Cable Gland with Cable (G1C) (100–240 VAC; AC3 Option: 100–277 VAC)

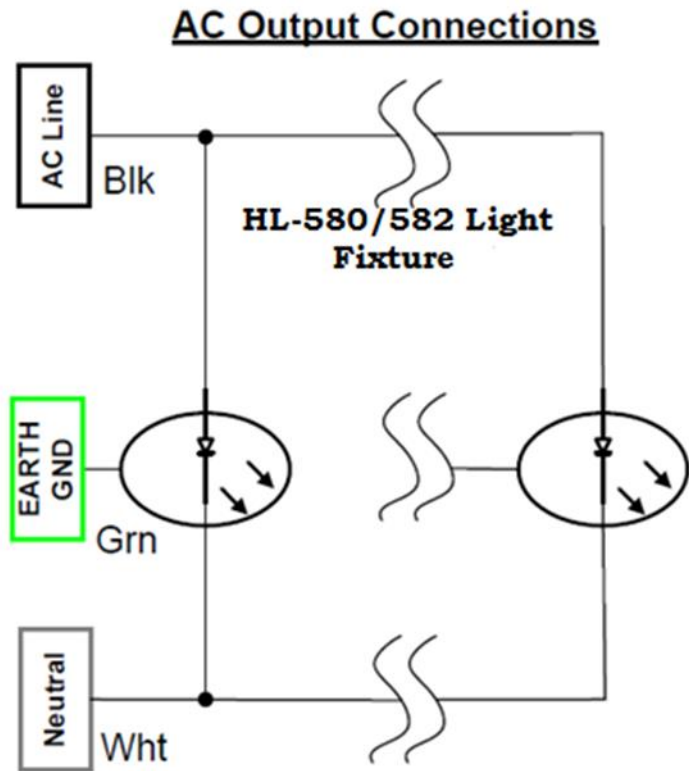
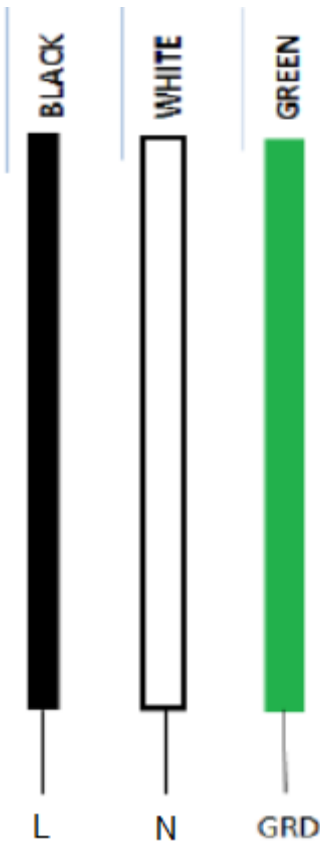
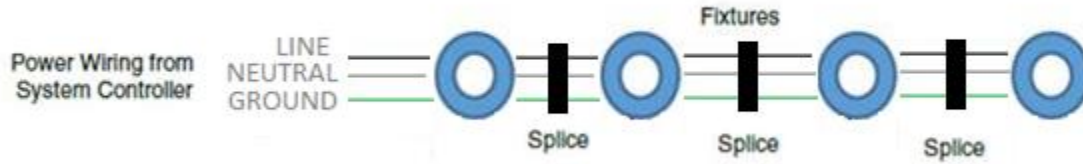



3.4.3 Wiring Diagram – AC-Powered LED Lights (IR and Non-IR), Dual Cable Glands, No Cable (G2NC) (100–240 VAC; AC3 Option: 100–277 VAC)

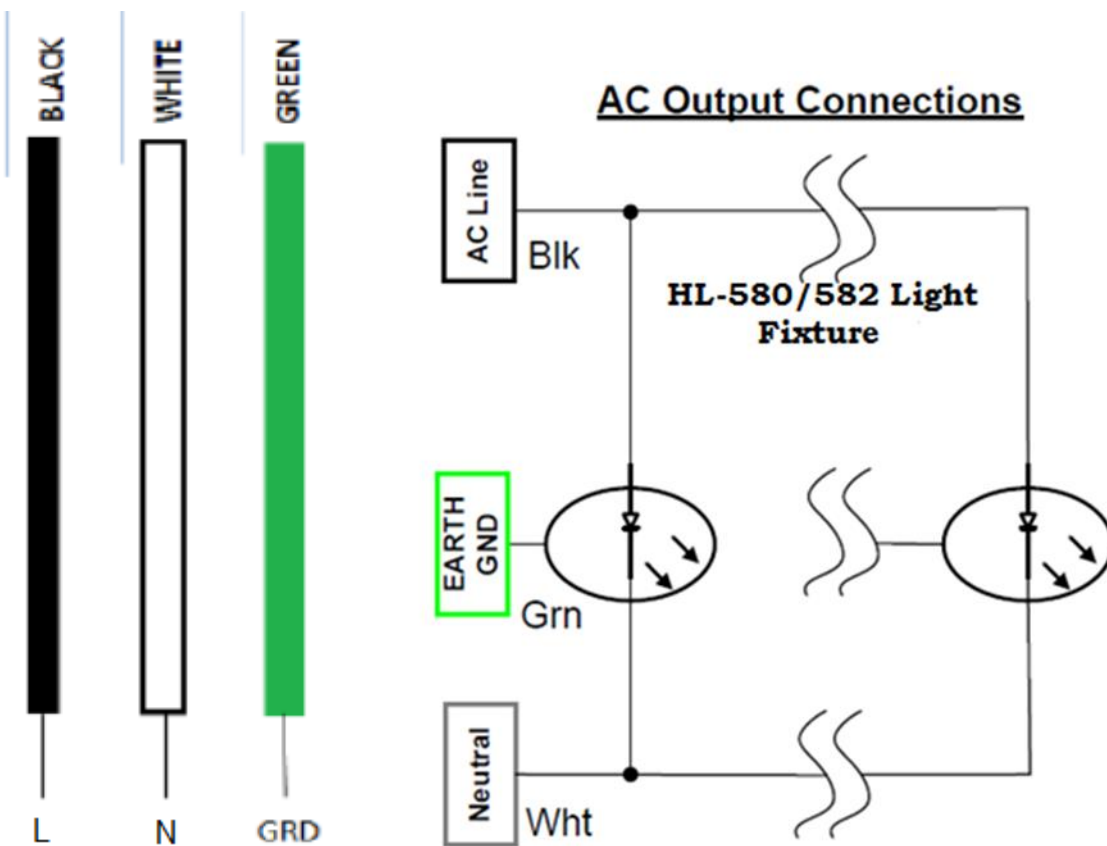
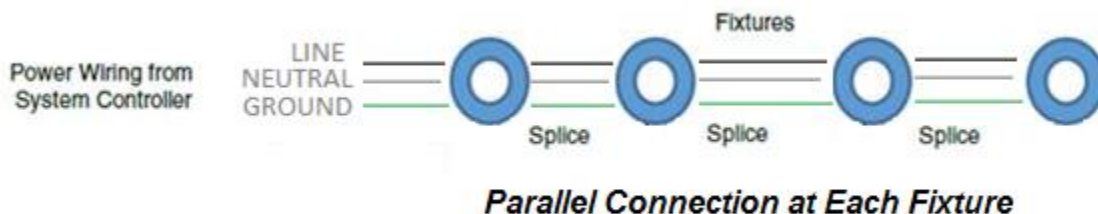



3.4.4 Wiring Diagram – DC-Powered LED Lights, with IR

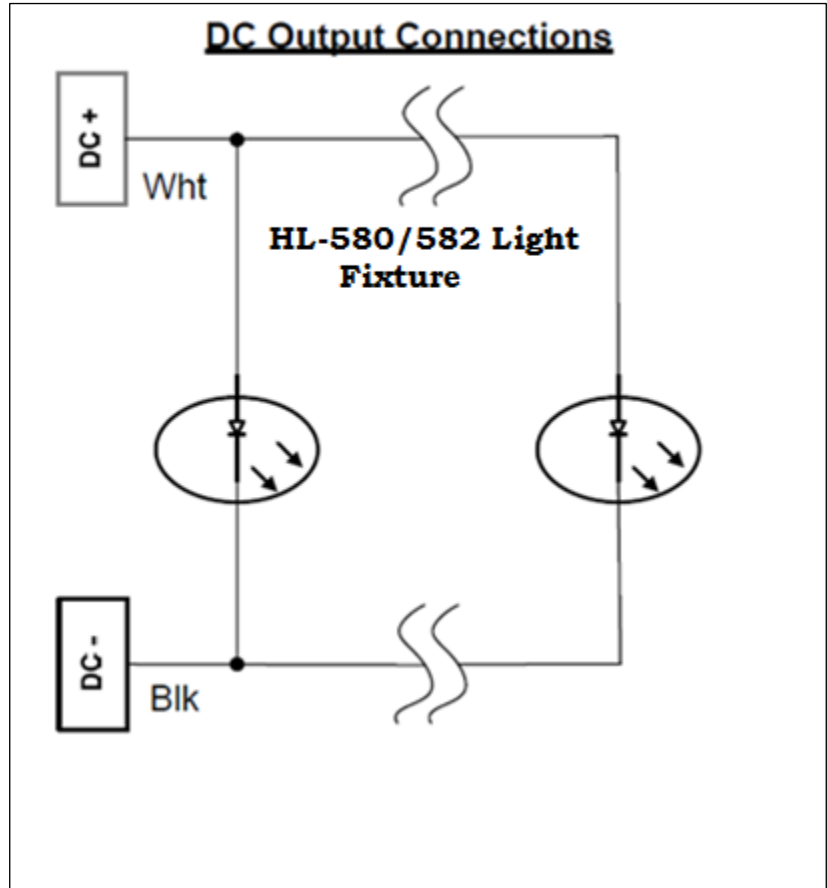



3.4.5 Wiring Diagram – DC-Powered LED Lights, Dimming, with IR

Note that on the Dimming lights with IR, only the visible light is dimmable, the IR stays at the same intensity.

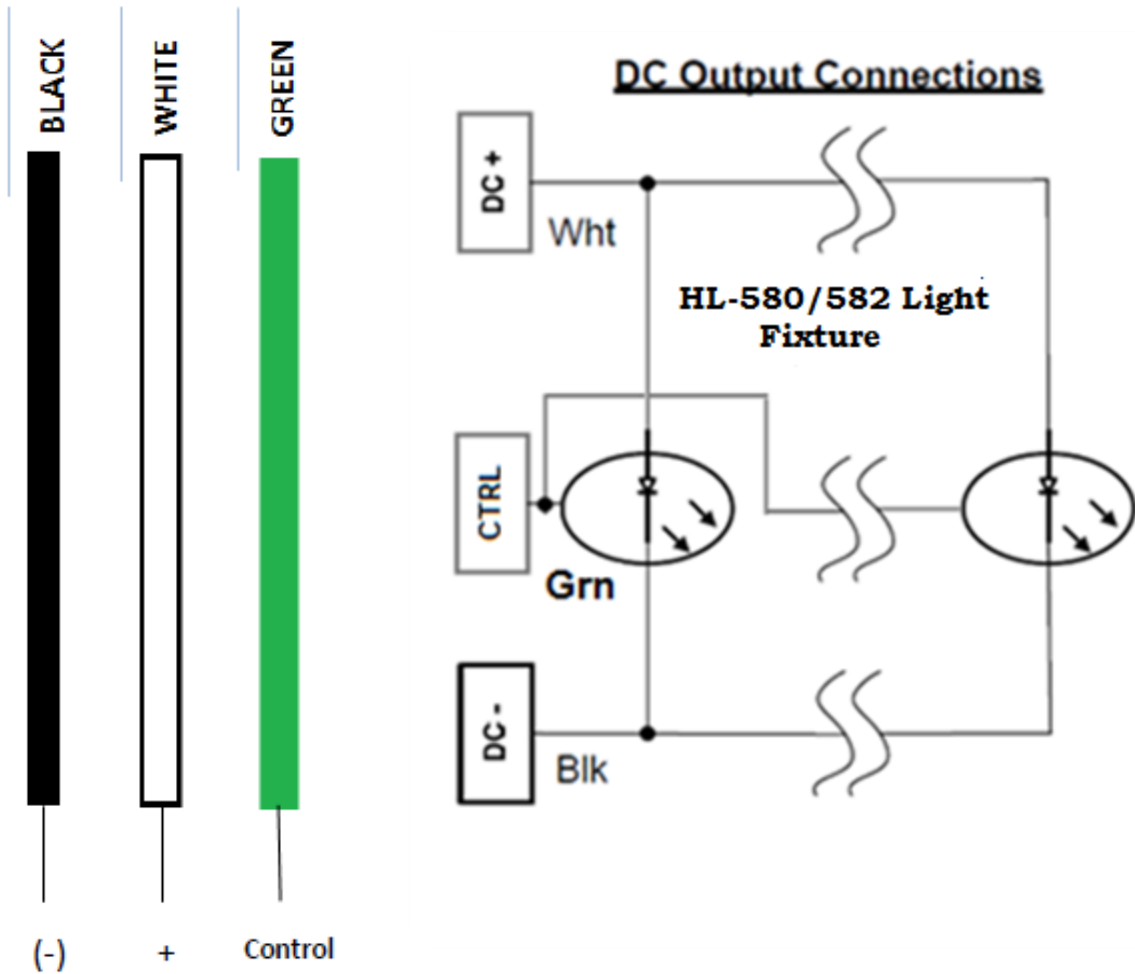



3.5 Installation

1. Position each light around the helipad perimeter as required by the site plans and specifications.
2. Refer to Figure 3 below for dimensions and distance in between holes.
3. Use four screws no larger than 3/8" (9.5mm). The length and type of screws will depend on the installation surface. Prior to bolting the fixtures, coat the bolt threads with marine grade anti-seize grease.

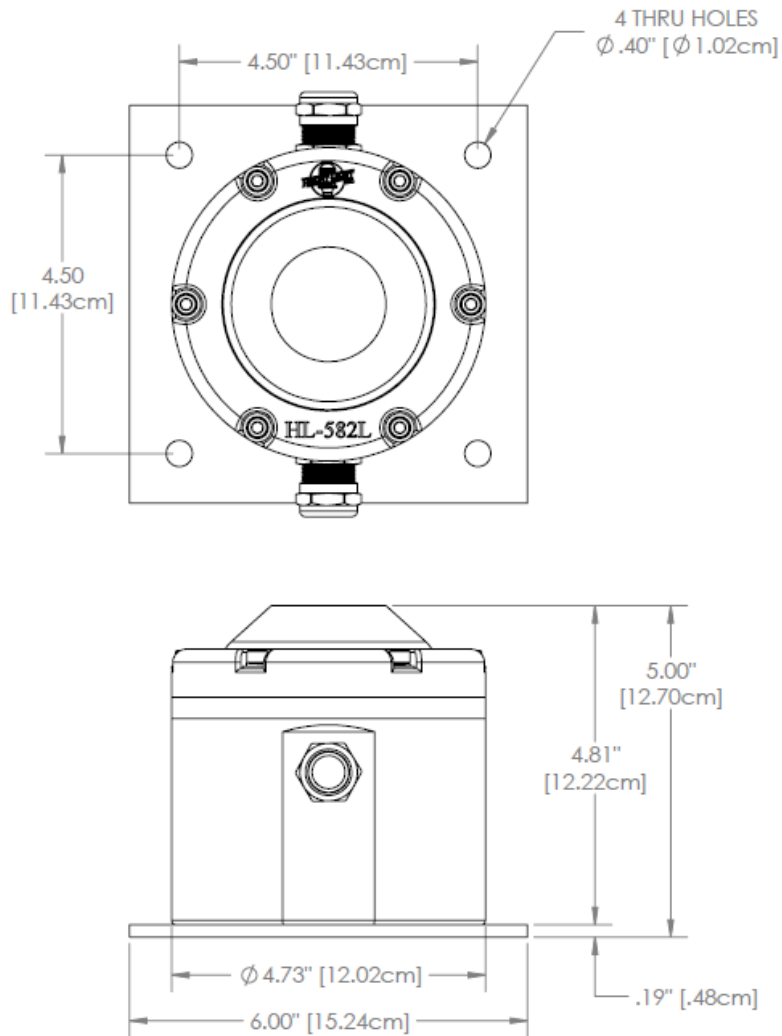

4. Maintenance

Recommended Practice:

- Verify the incoming power and confirm it matches the fixture's rated voltage.
- Verify that there is no condensation inside the prism.



- Check for loose wire connections.
- Check for presence of corrosion or chipped paint.
- Remove existing vegetation that can affect the lights visual range.
- Clean lens with glass cleaner if lenses are dirty.
- Adjust and reposition any misaligned fixtures.
- Check for improper ground elevation.
- Periodically verify cord grips are not loose and provide a water tight seal.

5. Replacement Parts

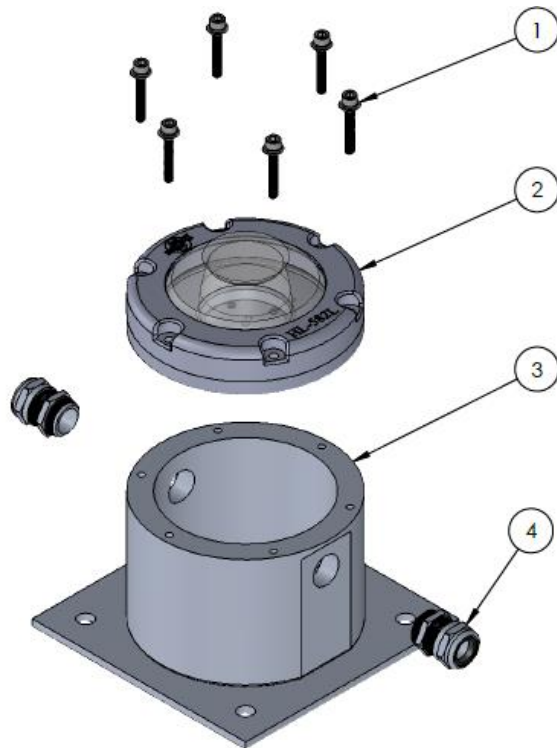

Replacement parts for Model 580

Item No.	Description	Part Number
1	Screw Kit 10-32 304 SS 1.25" Long	HL-582SCREWKIT
2	Upper Assembly	HL-580TOPKIT-X (x = color) HL-580TOPKIT-XIR
3	Lower Assembly	HL-580BOTTOMKIT HL-580BOTTOMKIT-IR
4	Cord Grip	27-CD20DA-BR
N/A	Gel Connector Kit	HL-582GCK

Replacement parts for Model 582

Item No.	Description	Part Number
1	Screw Kit 10-32 304 SS 1.25" Long	HL-582SCREWKIT
2	Upper Assembly	HL-582TOPKIT-X (x = color) HL-582TOPKIT-XIR
3	Lower Assembly	HL-582BOTTOMKIT HL-582BOTTOMKIT-IR
4	Cord Grip	27-CD20DA-BR
N/A	Gel Connector Kit	HL-582GCK



6. Limited Warranty

Duration of the Warranty: Flight Light Inc. warrants all of the goods which it has manufactured to be free of material defects for the following durations.

Lamps: For a period of 90 days from the date of shipment to Buyer. Product liability is limited to lamp replacement and does not include incidental labor.

FAA products: For a period of one year from the date of installation or two years from the date of shipment to Buyer.

LED Light Fixtures: For a period of 2 years from the date of shipment to Buyer. Complete Systems: Systems including at least one Flight Light Inc. Controller and one Flight Light Inc. LED Light Fixture, for a period of 5 years from the date of shipment to Buyer.

Buyer's Remedies: If any such goods are found to be materially defective within the warranty period, Flight Light Inc. agrees to attempt to repair, and if unable to repair, to replace the defective goods without charge to Buyer.

Buyer's remedy with respect to such goods is limited to repair or replacement. For goods not manufactured by FLI, Buyer agrees to accept as its sole remedy the warranty, if any, offered by the manufacturer or manufacturers of such goods. FLI makes no warranties, express or implied, other than those stated in this paragraph.

Warranty Exclusions: Flight Light Inc. shall not be liable under this warranty if any of the following conditions apply:

- 1) Unauthorized personnel attempt any repairs to Flight Light Inc. products without Flight Light Inc. consent.
- 2) Products are damaged by natural phenomenon, misuse, abuse, accident, alteration, or incorrect electrical current or voltage.
- 3) Products are improperly installed, or damaged in shipping.

Warranty Limitations

FLI makes no warranties, express or implied, other than those stated herein. FLI does not warranty the workmanship of the installer, damage caused by acts of nature, vandalism, improper installation, or damage caused by improper maintenance. The warranty period of LED fixtures covered under the 5-year system warranty is reduced to two years when fixtures are subjected to abrasive materials or chemicals. FLI reserves the right to either repair or replace any defective component covered under the terms of any of its warranties. FLI is not an engineering firm and makes no expressed or implied warranty as to the applicability of its products or systems in any specific situation, application or location: such decisions are the responsibility of the owner, design engineer and/ or others. Therefore, as to all goods sold by FLI, FLI hereby disclaims any implied warranty of merchantability or implied warranty of fitness for a particular purpose and Buyer agrees that FLI shall not be liable for any special, indirect, incidental, consequential or liquidated damages of any kind, whether the Buyer's or any other claim is based upon contract, tort or any other legal theory.