

# Flight Light Inc.

---

HL-600  
Heliport Inset Light  
Installation and Owner's Manual

---



Contents

- 1. About the manual..... 16
- 2. Safety Measures ..... 17
- 3. Installation Procedures..... 18
  - 3.1 Unpacking..... 18
  - 3.2 Installation Precautions and Recommendations..... 18
  - 3.3 Drainage System Requirements ..... 18
  - 3.4 Drainage System Design ..... 19
- 4. Electrical Wiring..... 26
- 5. Maintenance & Troubleshooting ..... 30



## **1. About the manual**

This manual contains the needed instructions to complete a successful installation. Failure to install the system properly will negatively impact the system's performance, shorten its life and may void the manufacturer's warranty.

The proper installation and operation of your system is our top priority. For that reason, this installation manual has been designed to guide you through each of the major steps of the in-pavement and electrical installation of the system. We recommend that a copy of the manual be given to both the design engineer and the installer of your system, well in advance of the actual installation.

The major steps covered in this manual include:

### **In-pavement Installation**

1. Proper Placement of Fixtures
2. Drainage System Requirements and Design
3. Base Can Installation guidelines

The installation and maintenance should be done by authorized personnel only.

For questions or guidance during the installation process, please contact our office as engineers and technician are always available to help you.

Phone number: 916-394-2800

OR send an email request to: [info@flightlight.com](mailto:info@flightlight.com)

## 2. Safety Measures

You must know whether your HL-600 light fixtures is powered by AC or DC before installing the fixture. AC LED lights work on a range of 100 to 240VAC if and DC models operate from 10 to 30VDC. The lights are designed to be installed in a parallel circuit, which maintains a constant voltage and brightness for all lights.

Ensure power is off before installing or servicing fixtures!

Follow the local electrical code!

Make sure the equipment is rated and approved for the environment in which you are intending to use it. Do not operate this equipment in humid, flammable, or explosive environments unless it has been rated for safe operation in these environments.

Use only electrical wire of sufficient gauge and insulation to handle the rated current and voltage demand.

Route electrical wiring along a protected path. Make sure they will not be damaged by moving equipment.

Protect components from harsh environment conditions.

Protect equipment with safety devices as specified by applicable safety regulations.

Before starting this equipment, check all safety interlocks, fire –detection systems, and protective devices such as panels and covers. Make sure all devices are fully functional. Do not operate the system if these devices are not working properly.

Never operate equipment with a known malfunction.

Do not attempt to operate or service electrical equipment if standing water is present.

Do not touch exposed electrical connections on equipment while the power is ON!

Wiring and electrical design should be authorized by an electrical contractor.

Wiring connections and wire splices must be done in a waterproof junction box.

### **3. Installation Procedures**

#### **3.1 Unpacking**

Each inset light is packed in its own box 9" x 9" x 5". Carefully remove the light from its box and inspect for damages. If any damages are found, file a claim with the carrier.

#### **3.2 Installation Precautions and Recommendations**

1. Verify that the drainage system is working properly by pouring water into the drain hole of each base can before pouring concrete and checking that the underlying drainage is absorbing the water. This should be done after the core drilling or trenching, but before the fixture is installed and the concrete is poured. The water absorption test is done prior to pouring concrete so that, if the drainage system is not performing properly, it can be repaired without having to remove and then re-pour the concrete.
2. Verify that the base cans have been installed level with the surface.
3. Base cans are shipped with a protective plywood cover, Part# BA-PLCVR-3/4. The cover is used to protect the flange ring and keep debris out of the base can during installation, whenever the fixtures need to be removed for routine maintenance, during road resurfacing or during fixture shipment. After installation, the plywood covers should be marked, "DO NOT DISCARD", and stored in a safe location until needed.

#### **3.3 Drainage System Requirements**

The truism that water and electricity don't mix holds for Lighting Systems. Pavement is subject to many sources of moisture, the most serious of which is ground water. The Flight Light Inc. lighting system is designed to prevent water and water vapor from making contact with electrical conductors, contacts and connections. Fixtures used in the Flight Light Inc. system employ seals that prevent moisture from entering the light fixture. The connectors used are waterproof and provide connection between the fixture, and control system without fear of electrical shorting to ground. However, water within the base cans, left for long periods of time, may create problems. Standing water in the base can is especially undesirable in colder climates because of damage that can be done when water freezes and expands. To prevent problems caused by standing water in the base cans a proper drainage system must be designed and prior to the electrical installation of the fixtures and pouring of concrete. Failure to install a proper drainage system may result in damage to the system components.

### 3.4 Drainage System Design

A number of drainage system designs may be used to provide proper drainage for the light system. Two types of drainage systems are typically used in the installation of the system:

- A. Modified French Drain – This drain typically consists of a 1 1/2 inch diameter PVC pipe discharging into a drain rock section, which is installed directly under the drain hole of the base can. See Figures 1 and 2 that are located on pages 8 and 10 respectively.
- B. Piped Drain - This drain provides positive drainage from each base can through a pipe system that carries any water that gets into the system off the edge of the street where it will drain into an open ditch, storm drain system, or other drainage facilities that are available. See Figure 3 located on page 12. If no existing drains are available, then an excavation can be made at the outside of the street section and this excavation filled with drain rock. This will serve as a retention area for water produced in the system and an area to allow for percolation of this water into the surrounding ground.

All installations should be done by qualified individuals according to all federal, state, and local electrical codes which apply. All information contained in this manual is intended to provide general guidance and information.

Because local codes, soil conditions and weather conditions are unique to each location TSC will not specify a drainage system for a specific installation. The typical installations described in the following pages are provided as general guidelines and may not apply at your site location. Refer to the Design Engineer's drawing for the drainage system specified for your specific installation. If one has not been prepared, ask the Project Engineer to prepare one before proceeding with the installation.

#### **A. Base Can Installation – Core Drill and Saw Cut (Figure 1)**

- 1. Remove the plywood base covers from the base can, mark them "Do Not Discard", and store them in a safe location.
- 2. Begin the core drilling (typically 12-to-14-inch diameter and the depth will vary per terrain and/or suggestion of the civil engineer/contractor) and saw cut process. Holes should be drilled at fixture locations. Saw cuts should then be made to allow room for the fixture power cables (typically 3½" deep x ½" wide). Saw cuts are made parallel to the direction of the pedestrian travel and in line with the centers of the conduit holes.

3. In this installation, the base can fixture cable conduit holes will not be used with conduit. However, the fixture cables will pass from the edge of the saw cut into these holes. The cables will be held in place and the holes sealed with a sealing compound such as *Dollie Duct Seal* compound, or equivalent.
4. Prepare the drainage system specified by the design engineer. With this type of installation, it is impractical to install a piped drain system. It is recommended that the modified French drain system be utilized. Refer to figure 1 on page 8.
5. Install the base can drain fittings provided into each base can drain hole. Run 1 1/2 inch size pipe, Schedule 40 PVC, into the fittings of the base can. Pipe length should be cut so that the pipe, when positioned over the drain, extends approximately 3 to 4 inches into the drain rock.
6. Suspend the base cans so they are level with the surface of the pavement and supported so that they are rigid and won't move during the concrete pour. Base cans should be oriented so that the fixture optics will be aligned parallel with the traffic lane. Use of mounting jigs is recommended for proper alignment of base cans. Consult the design plans for the preferred method of base can suspension for your installation.
7. Test the drainage system by pouring water into the base can at each fixture location before concrete is poured. Pour enough water to verify that the underlying ground is absorbing the water. If the base can is not draining properly, modifications to the drainage system will be necessary. In this case consult with your design engineer before proceeding. Once you're satisfied that the drain is working properly, move on to the next step.
8. Install the fixture cables. Run fixture power cables to each base can, one black wire, one white wire for non-dimming fixtures. Run one black wire, one white wire and one green wire for dimming fixtures. If grounding is required by local code, run an additional grounding wire to each base can. The ground wire can be attached to the base can using the ground strap provided at the bottom inside of each base can.
9. Make sure that the filter fabric is in place above the drain rock to prevent slurry from clogging up the drain. Then encase the base cans and drainage system in concrete. It is recommended that at least 6 inches of concrete be used below the base. Fill saw cuts with Traffic Loop Sealant, or equivalent.
10. After the concrete has hardened, remove the mounting jigs, clean out base cans, and replace protective plywood covers until fixtures are ready for installation.

**Figure 1: Base Can Installation – Core Drill and Saw Cut**

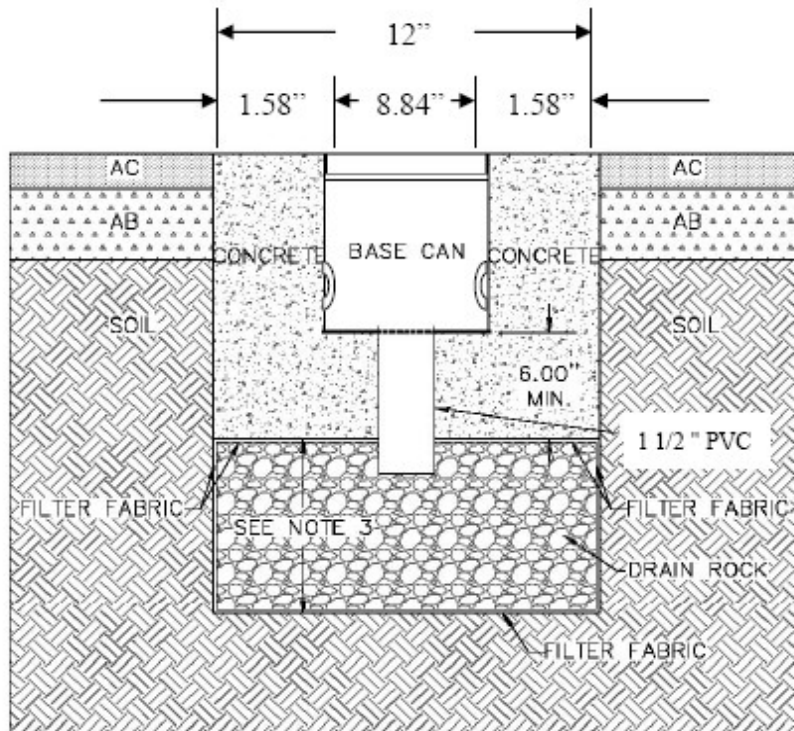

Drawing not to scale

**Notes:**

1. Drain rock shall be graded from 1 inch to ¼ inch.
2. Drain rock shall be encased in a filter fabric material to avoid soil infiltration into the drain rock.
3. Recommended depth of drain rock unit varies dependent upon the type of existing soils.
  - a. Where existing soils are granular and permeable the depth of the drain rock unit can be limited to 1 foot.
  - b. Where existing soils are fine graded and have low permeability the depth of the drain rock unit should be increased to 3 feet or greater to provide a reservoir for short term retention. Refer to engineering plans for the requirements specified by the project engineer.
4. Concrete shall be 3/8 inch maximum aggregate mix, use a minimum of seven sacks of cement per cubic yard of concrete and poured from a height of approximately 5 inches above the can. Concrete should only be poured from one side. Vibrate or rod concrete to completely fill the area below and on all sides of the base can. When concrete is visible on the side opposite to the side that concrete is being poured from, pouring can commence from alternate locations.
5. Abbreviations: Asphalt Concrete (AC), Aggregate Base (AB).

**B. Base Can Installation – Trench and Fill – Option 1 (Figure 2)**

1. Remove the plywood base covers from the base can, mark them "Do Not Discard", and store them in a safe location.
2. Begin trenching process. After trenching is completed along fixture locations, prepare the drainage system as specified by the design engineer. Refer to figure 2 on page 10.
3. Install the base can drain fittings provided into each base can drain hole. Run 1 1/2 inch size pipe, Schedule 40 PVC, into the fittings of the base can. Pipe length should be cut so that the pipe, when positioned over the drain, extends approximately 3 to 4 inches into the drain rock.
4. Suspend the base cans so they are level with the surface of the pavement and supported so that they are rigid and won't move during the concrete pour. Base cans should be oriented so that the fixture optics will be aligned parallel with the traffic lane. Use of mounting jigs is recommended for proper alignment of base cans. Consult the design plans for the preferred method of base can suspension for your installation.
5. Test the drainage system by pouring water into the supported base can at each fixture location. Pour enough water to verify that the underlying ground is absorbing the water. If the base can is not draining properly, modifications to the drainage system will be necessary. In this case consult with your design engineer before proceeding. Once you're satisfied, move on to the next step.
6. Install fixture cable conduit. Run 1 inch pipe size, Schedule 40 PVC, between each base can. PVC conduit should fit snugly into the grommets located at each base can conduit hole. Complete installation by running conduit from the last base can in the system to the system controller, as specified by the design engineer.
7. Install the fixture cables. Run fixture power cables through the conduit into each base can, one black wire and one white wire for non-dimming fixtures. Run one black, one white and one green wire for dimming fixtures. If grounding is required by local code, run an additional wire through the conduit to each base can. The ground wire can be attached to the base can using the ground strap provided at the bottom inside of each base can.
8. Make sure that the filter fabric is in place above the drain rock to prevent slurry from clogging up the drain. Then encase the base cans and drainage system in concrete. It is recommended that at least 6 inches of concrete be used below the base.
9. Backfill the trench with specified material, compact and cover per the designer's specifications, taking care not to damage conduit or drainage system. Remove mounting jig, clean out base can and replace protective plywood covers until fixtures are ready for installation.
10. After the concrete has hardened. Remove the mounting jigs, clean out base cans, and replace the protective plywood cover until fixtures are ready for installation.

**Figure 2: Base Can Installation – Trench and Fill (Option 1)**

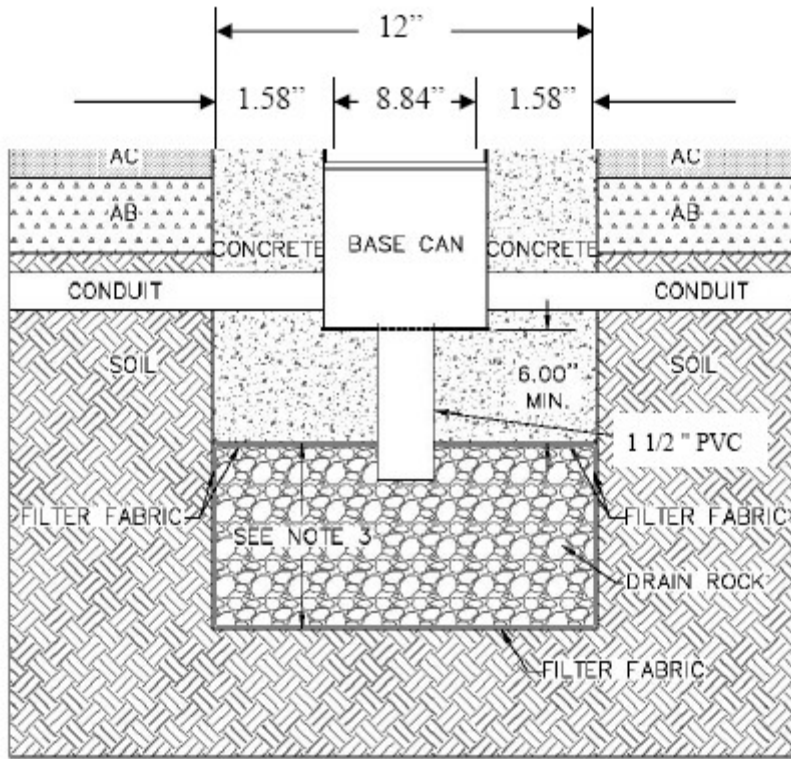

**Notes:**

1. Drain rock shall be graded from 1 inch to ¼ inch.
2. Drain rock shall be encased in a filter fabric material to avoid soil infiltration into the drain rock.
3. Recommended depth of drain rock unit varies dependent upon the type of existing soils.
4. Where existing soils are granular and permeable the depth of the drain rock unit can be limited to 1 foot.
  - a. Where existing soils are fine graded and have low permeability the depth of the drain rock unit should be increased to 3 feet or greater to provide a reservoir for short term retention. Refer to engineering plans for the requirements specified by the project engineer.
  - b. Concrete shall be 3/8 inch maximum aggregate mix, use a minimum of seven sacks of cement per cubic yard of concrete and poured from a height of approximately 5 inches above the can. Concrete should only be poured from one side. Vibrate or rod concrete to completely fill the area below and on all sides of the base can. When concrete is visible on the side opposite to the side that concrete is being poured from, pouring can commence from alternate locations.
5. Abbreviations: Asphalt Concrete (AC), Aggregate Base (AB)
6. **Note: Drawing not to scale.**

### C. Base Can Installation – Trench and Fill – Option 2 (Figure 3)

1. Remove the plywood base covers from the base can, mark them “Do Not Discard”, and store them in a safe location.
2. Begin trenching process. After trenching is completed along fixture locations, prepare the drainage system as specified by the design engineer. Refer to Figure 3 on page 12.
3. Install the base can drain fittings provided into each base can drain hole. Suspend the base cans so that they are level with the surface of the pavement and aligned parallel with the traffic lane. Use of mounting jigs is recommended for proper alignment of base cans. Consult the design plans for the preferred method of base can suspension for your installation, making sure that they are rigid and won't move during the concrete pour.
4. Install drain conduit. Run 1 1/2 ", *Schedule 40 PVC*, from each base can fitting into the proper coupling (right angle bend, T-adapter, etc.). Connect all couplings together using the proper length PVC pipe. Run the end of the drain conduit into the drainage system, ditch, or leaching pit. The drainage conduit pipe should have a slight negative slope.
5. Test the drainage system by pouring water into the supported base can at each fixture location. Pour enough water to verify that the drainage system is absorbing the water. If the base can is not draining properly, modifications to the drainage system will be necessary. In this case consult with your design engineer before proceeding. Once satisfied, move on to the next step.
6. Install fixture cable conduit. Run 1 inch pipe size, *Schedule 40 PVC*, between each base can. PVC conduit should fit snugly into the grommets located at each base can conduit hole. Complete installation by running conduit from the last base can in the system to the system controller, as specified by the design engineer.
7. Install the fixture cables. Run fixture power cables through the conduit into each base can, one black wire and one white wire for non-dimming fixtures. Run one black wire, one white wire and one green wire for dimming fixtures. If grounding is required by local code, run an additional wire through the conduit to each base can. The ground wire can be attached to the base can using the ground strap provided at the bottom inside of each base can.
8. Encase the base cans and drainage system in concrete. It is recommended that at least 6 inches of concrete be used below the base. After the concrete has hardened, remove the mounting jigs, clean out base cans, and replace the protective plywood covers until fixtures are ready for installation.
9. Backfill the trench with specified material, compact and cover per the designer's specifications, taking care not to damage conduit or drainage system.

**Figure 3: Base Can Installation – Trench and Fill (Option 2)**

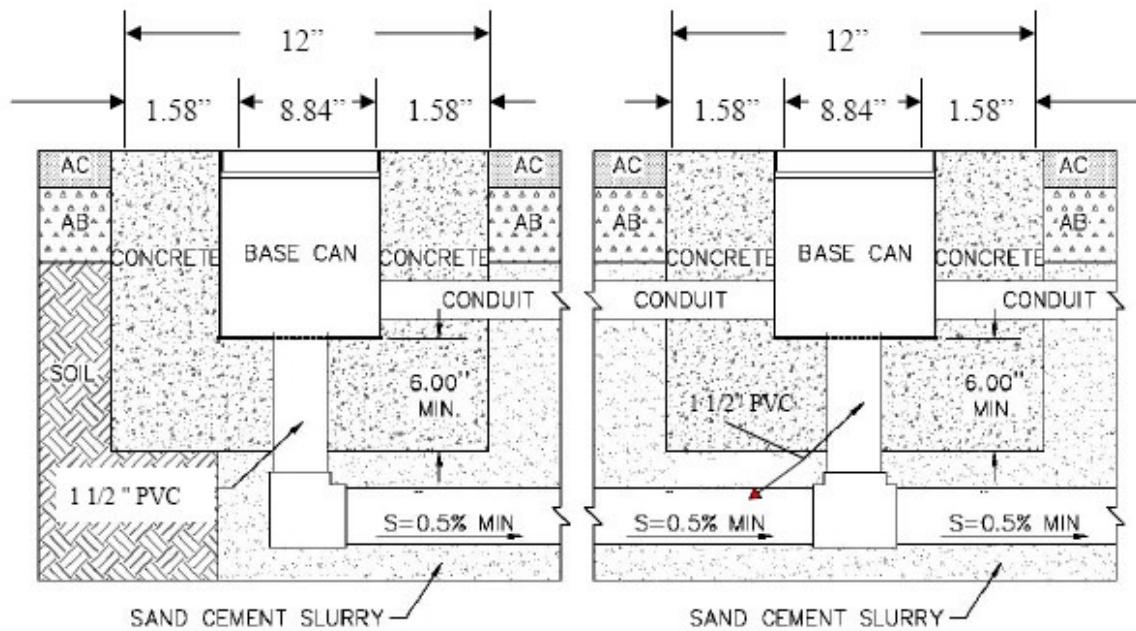

**Notes:**

1. The 1 1/2 inch PVC drain conduit is used to discharge water into the existing drainage system, existing ditches or if necessary a leaching pit.
2. The leaching pit can consist of a 36 inch diameter drilled hole carried to a depth of 6 to 10 feet and filled with drain rock.
3. Abbreviations: Asphalt Concrete (AC), Aggregate Base (AB), Slope (S).
4. Drainage slopes of 1% are typical.
5. Drawing not to scale.

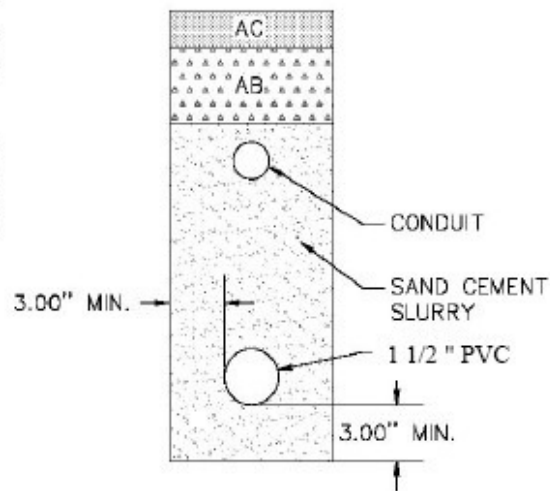

6. Concrete shall be 3/8 inch maximum aggregate mix, use a minimum of seven sacks of cement per cubic yard of concrete and poured from a height of approximately 5 inches above the can. Concrete should only be poured from one side. Vibrate or rod concrete to completely fill the area below and on all sides of the base can. When concrete is visible on the side opposite the side that concrete is being from, pouring can commence from alternate locations.

## 4. Electrical Wiring

1. Ensure the power is OFF before installing or servicing the fixture. The fixtures are wired in parallel according to the following diagram:
2. The gauge of the electrical wire is to be calculated by the electrical engineer and should be sufficient to handle the rated current, voltage demand, and distance to the power supply.

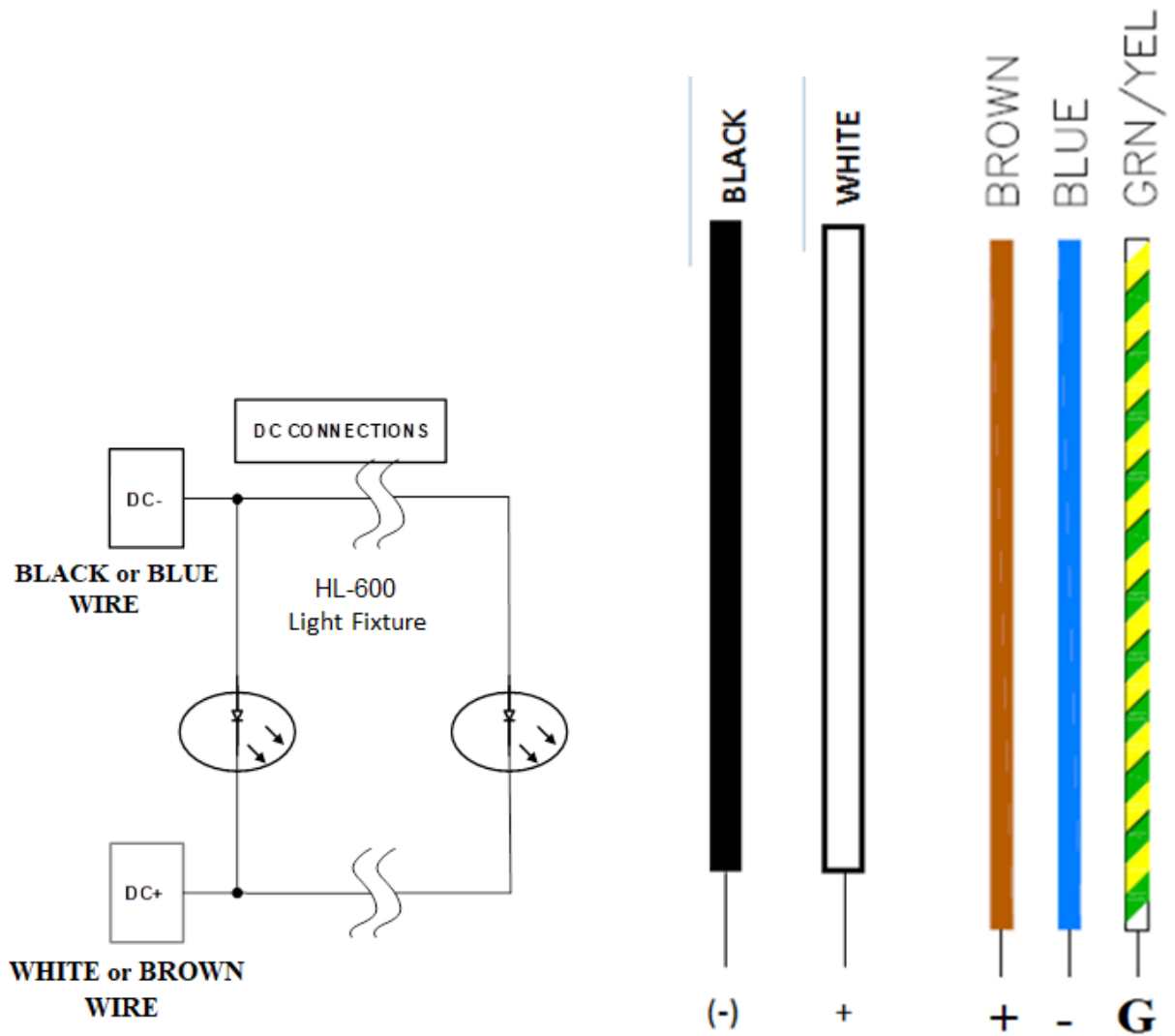

**DC FIXTURE (NON-DIMMING)**

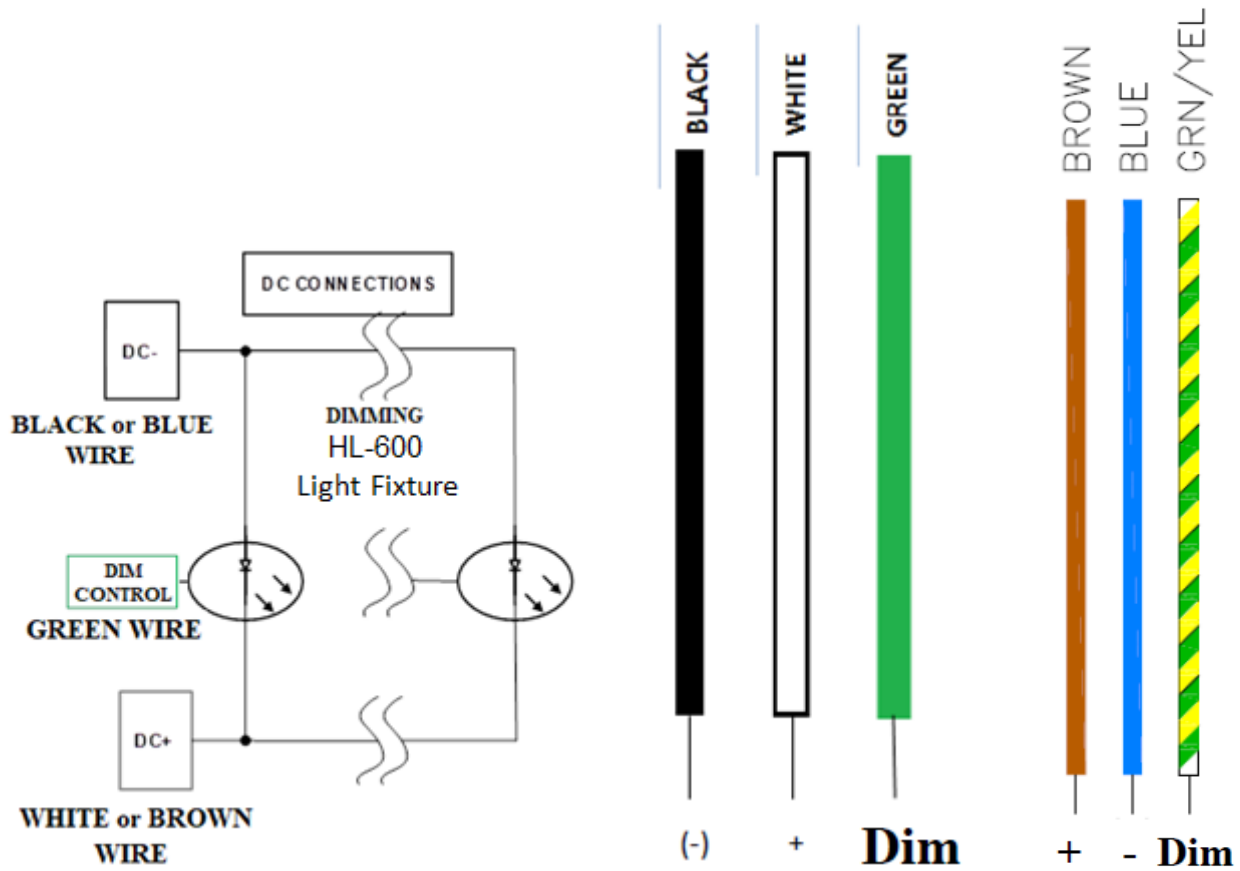

**DC FIXTURE (DIMMING)**

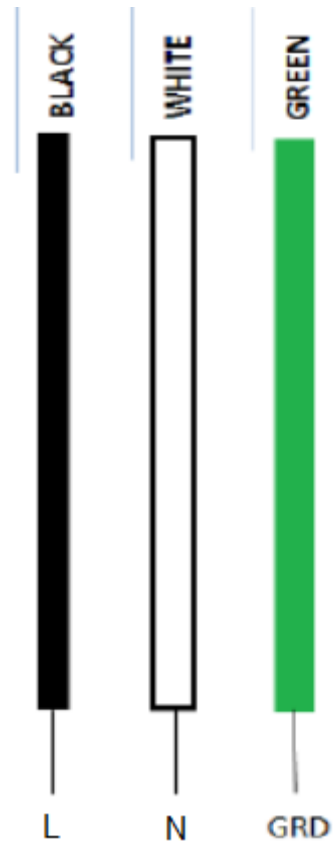
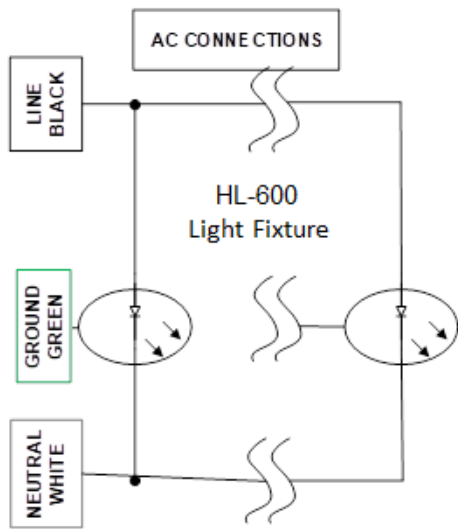

**AC FIXTURE**

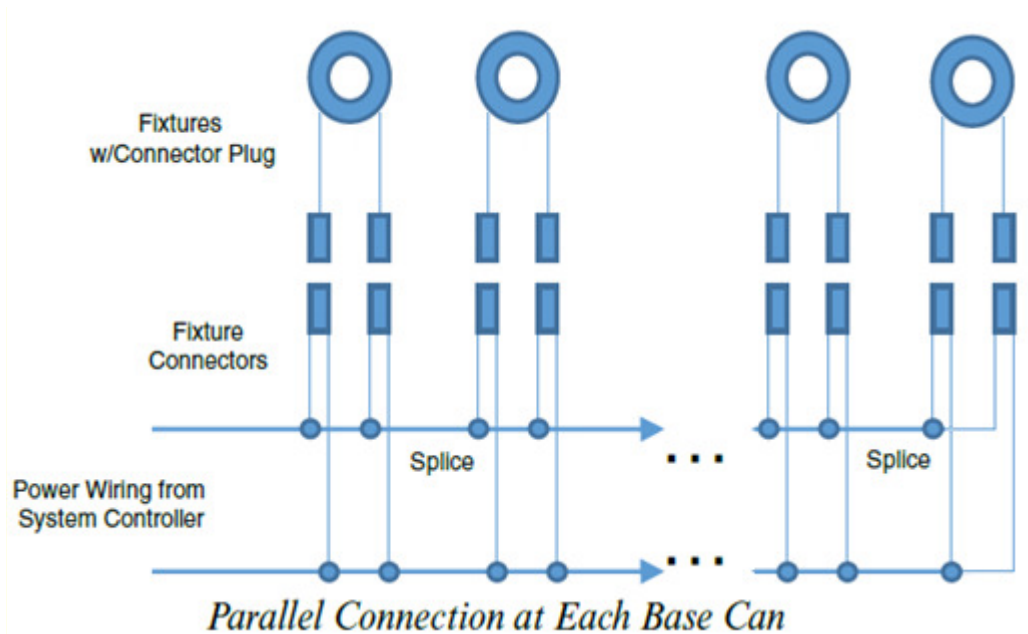

**AC & DC FIXTURES**

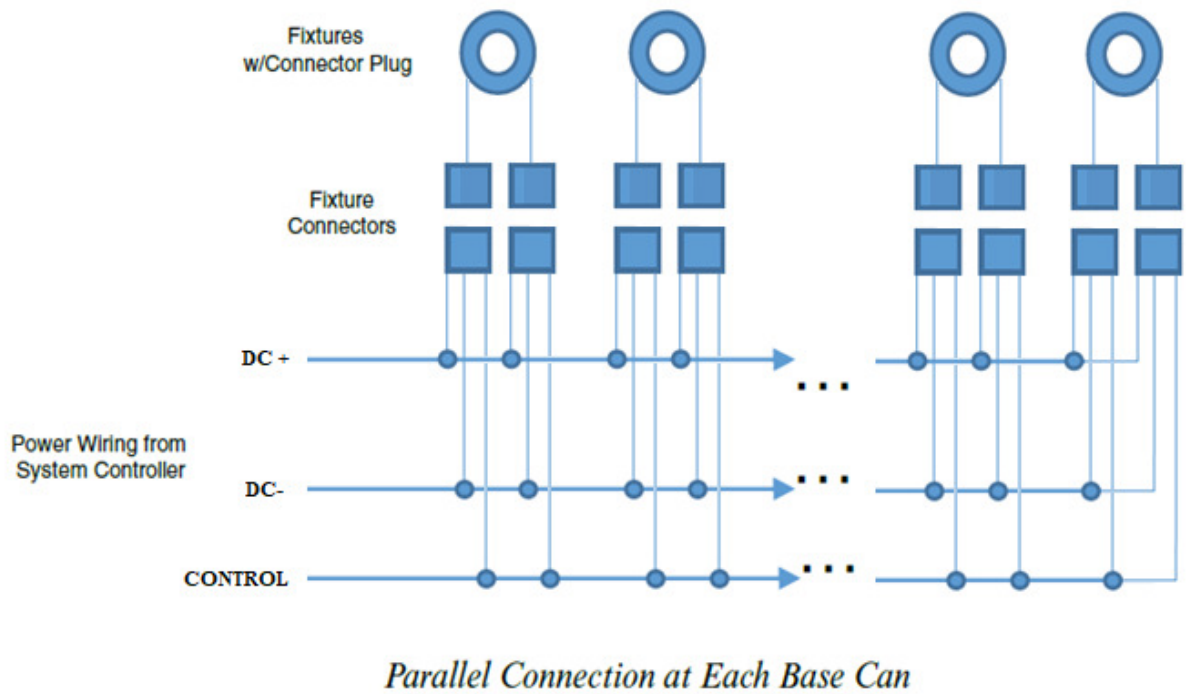

**DC FIXTURES WITH DIMMING**

## 5. Maintenance & Troubleshooting

The following general maintenance procedures will help ensure maximum performance and long component life:

- Lenses should be cleaned periodically as an accumulation of dirt, can decrease light output.
- Line voltage should be checked at the fixture and compared with the power supply to be sure it is within the prescribed limits.
- Make certain polarity is correct for DC light fixtures.
- Be sure the fixtures are properly grounded.
- Every six (6) months inspect the lights for broken seals or cracks.
- The replacement of the LED it's only recommended on failure.

### Appendix A – Core Drill and Saw Cut Installation Pictures



**Fixture Layout**

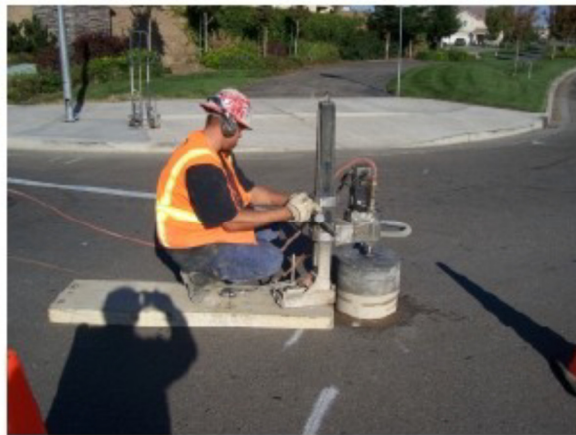

**Core Drill**



**Saw Cut**



**Drainage**



**Mounting Jig Setup**



**Base Can Alignment**



**Base Can in Concrete**



**Plywood Protective Cover**



**Fixtures Placed in Base Cans**



**Flight Light Inc.**  
**2708 47th Ave.**  
**Sacramento, California, U.S.A.**  
**95822-3806**

**PH (916) 394-2800**  
**EM [info@flightlight.com](mailto:info@flightlight.com)**