



**CHAPI User Instructions**

**48VDC INPUT SYSTEM**

2708 47<sup>th</sup> Ave  
Sacramento, CA 95822  
(916) 394-2800

## Table of Contents

Section	Description
1.0	Introduction
1.1	Overview
1.2	Safety Considerations
1.3	Reference Documents
2.0	System Description and Operation
2.1	System Description
2.2	System Operation
3	Installation
3.1	Instructions
3.1.1	Light Housing Assembly Footer and Mounting Pad Installation
3.1.2	Controller Installation
3.1.3	Interconnect Wiring
3.1.4	Input Power Wiring
3.1.5	Night Mode Dimming
3.1.6	Alignment of the Light Housing Assemblies
3.1.7	Flight Testing
4	Maintenance and Troubleshooting
5	Warranty

## **1.0 Introduction**

### **1.1 Overview**

Your Flight Light, Inc. LED CHAPI (Cramp's Helicopter Approach Path Indicator according to legacy) has been designed to provide years of service if the instructions in this guide are followed carefully. This guide contains the information necessary to install, operate and maintain your Flight Light, Inc. LED CHAPI. It is intended for use by qualified electrical contractors and engineers to facilitate new installations.

The objective of the CHAPI is to provide visual approach path indication to a helicopter pilot in Visual Flight Rule (VFR) weather conditions. A CHAPI is similar to an FAA L-881 Approach Path Indicator product except the CHAPI is intended for helipad use. The CHAPI is a visual aid and may be used with or without electronic landing aids, such as an Instrument Landing System (ILS). The typical glide slope for a helicopter approach is  $6^{\circ} \pm 0^{\circ}30'$  instead of the  $3^{\circ}$  used for airplane landing.

The product name CHAPI is a legacy term derived from a veteran pilot who had a product need which has evolved to its present state.

### **1.2 Safety Considerations**

Please adhere to the following recommendations for installing and maintaining your Flight Light, Inc. LED CHAPI.

- Anyone working on this product should be a Qualified Person according to NEC (2011 or latest version) Article 100.
- Installation and maintenance shall be conducted in accordance with all local codes and authorities.
- Use the proper wiring gauge according to Ampacities listed in NEC Table 310-16.
- Route electrical wiring along a protected path, away from sources of heat.
- Protect components from damage, wear, and harsh environment conditions.
- Always use the required personal protective equipment (PPE) and follow safe electrical work practices.
- Only properly-trained personnel who are familiar with PAPI, APAPI or CHAPI equipment are permitted to install and service this equipment.

### **1.3 Reference Documents**

- NFPA 70E, Electrical Safety Requirements for Employee Workplaces.
- National Electrical Code (2011 or latest version)
- OSHA 29 CFR, Part 1910, Occupational Health and Safety Standards
- ANSI/ NFPA 79, Electrical Standards for Metalworking Machine Tools.

## 2.0 System Description and Operation

### 2.1 System Description

The Flight Light, Inc. LED CHAPI system consists of three main components:

- Controller/Power Adapter – Utilizes 48VDC input power to power the control circuitry for the approach light output. A photocell is used according to FAA Advisory Circular 150/5345-28G section 3.10.6. A Radio Control option similar to an FAA L-854 is available for heliports with infrequent operation.
- Light Housing Assemblies (LHA) – For a heliport, only two LED boards (lamps) are required per unit. Two Light Housing Assemblies are necessary to provide a pilot with glide slope information. A Tilt Switch is mounted in each LHA which will turn off power per FAA Advisory Circular 150/5345-28G section 3.9.5.
- Mounting Hardware – Included with your purchase is a hardware kit which includes the LHA filters, adjustable support legs and Aiming Devices to help install and align the LHA.

A System Diagram for the AC-powered version is presented in Figure 2 on the next page. A System Diagram for the Solar-powered version is presented in Figure 3.

### 2.2 System Operation

The CHAPI provides a visual presentation of glide slope to a helicopter pilot according to Figure 1 below. The green portion of the LHA filter provides a 1° vertical window to indicate the correct approach path is used.

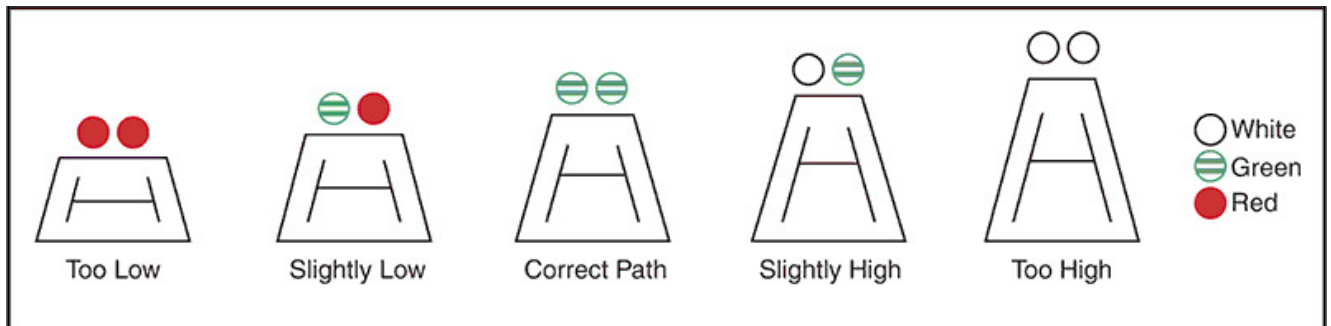

**Figure 1 - CHAPI Visual Display to Pilot**

A Tilt Switch Interlock Circuit automatically turns all LED lights OFF if a Light Housing Assembly is raised or lowered for longer than 10 seconds according to FAA Advisory Circular 150-5345-28G.

A Photocell is installed to provide automatic LHA intensity control per FAA Advisory Circular 150-5345-28G.

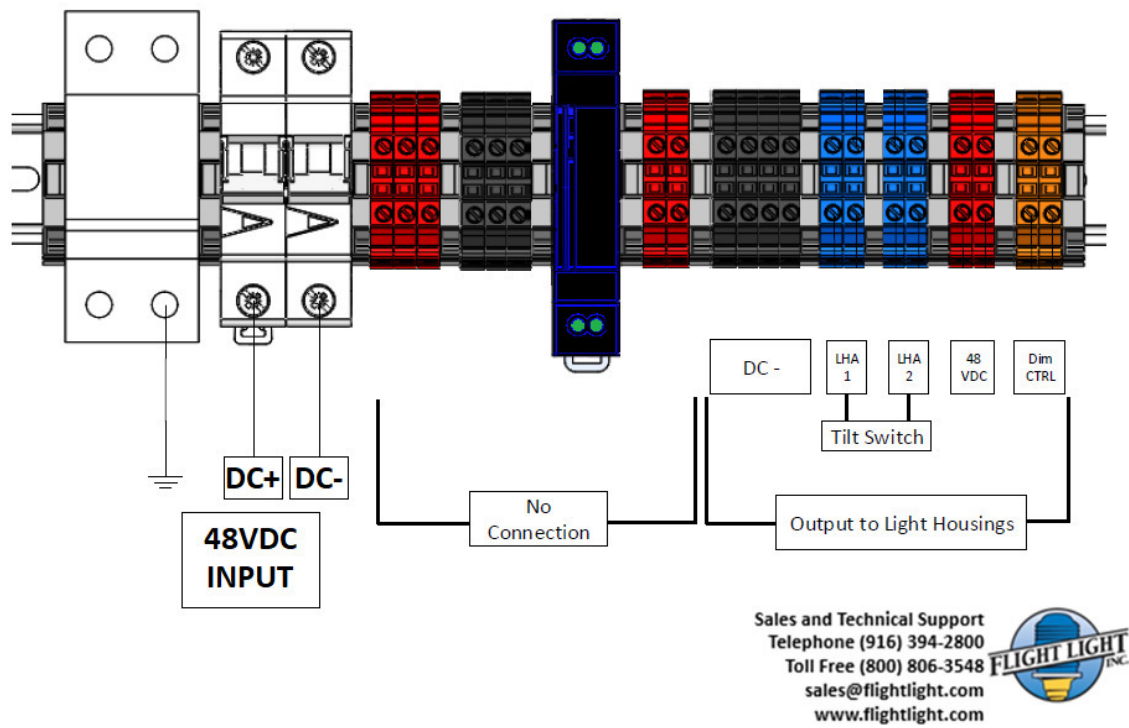

**Figure 2 – Power Adapter Terminal Blocks (48VDC Input System)**

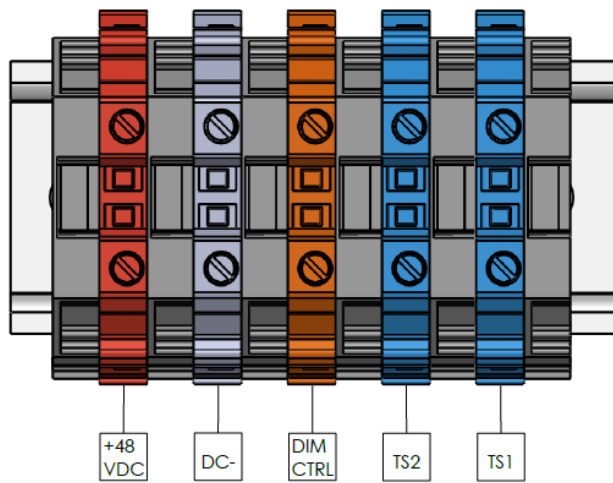

**Figure 3 – LHA Terminal Blocks (48VDC Input System)**

## **3.0 Installation**

### **3.1 Instructions**

Remove the packaging from the hardware kit provided with your CHAPI. The following steps are required to insure proper installation and maximum performance. Consultation and approval with a Civil Engineer is highly recommended for proper installation.

For siting information, please refer to chapter 5 of FAA document titled “Visual Guidance Lighting Systems”.

- Installation of the LHA footers and mounting pads.
- Installation and mounting of the Controller.
- Interconnect wiring between your Controller and the LHA’s.
- Input power wiring to your Controller.
- Alignment of the Light Housing Assemblies.
- Flight Test.

#### **3.1.1 Installation of the LHA Footers and Mounting Pads**

The recommended location for installing the CHAPI Light Housing Assembly is shown in Figure 4. The size of the helipad is dependent on your location and the maximum rotor diameter. The 3.28 foot dimension listed in Figure 4 is important to help locate the CHAPI nearest the helipad and assist helicopter pilots.

After the elevation and exact physical location of the light boxes has been determined, footers should be prepared as depicted in drawing FLP28407A (see Figure 5). After the footers have been set up, the EMT (2") legs should be cut. Because of the legs and mounting hardware, 16" is the minimum height that the center of the light box will be above the mounting surface. To determine the length to cut the EMT legs, subtract 11.25" from the height of the proposed mounting center of the light box lens, above the mounting pad. Mount the light boxes on the pads.

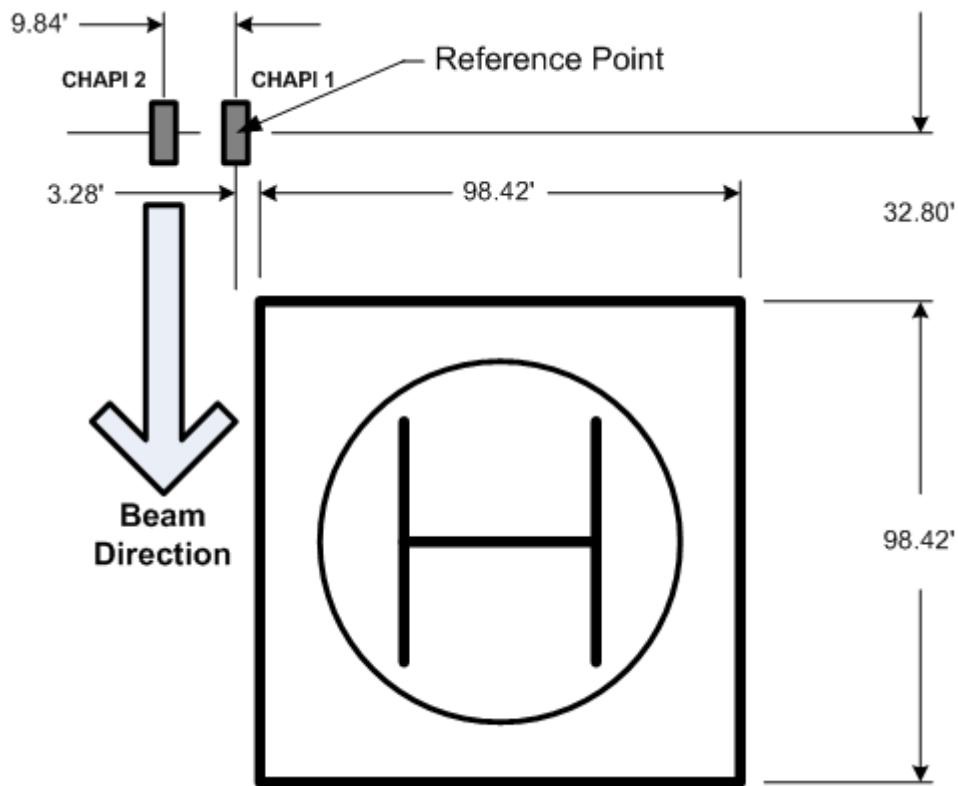

**Figure 4 – Typical CHAPI Light Housing Installation Diagram**

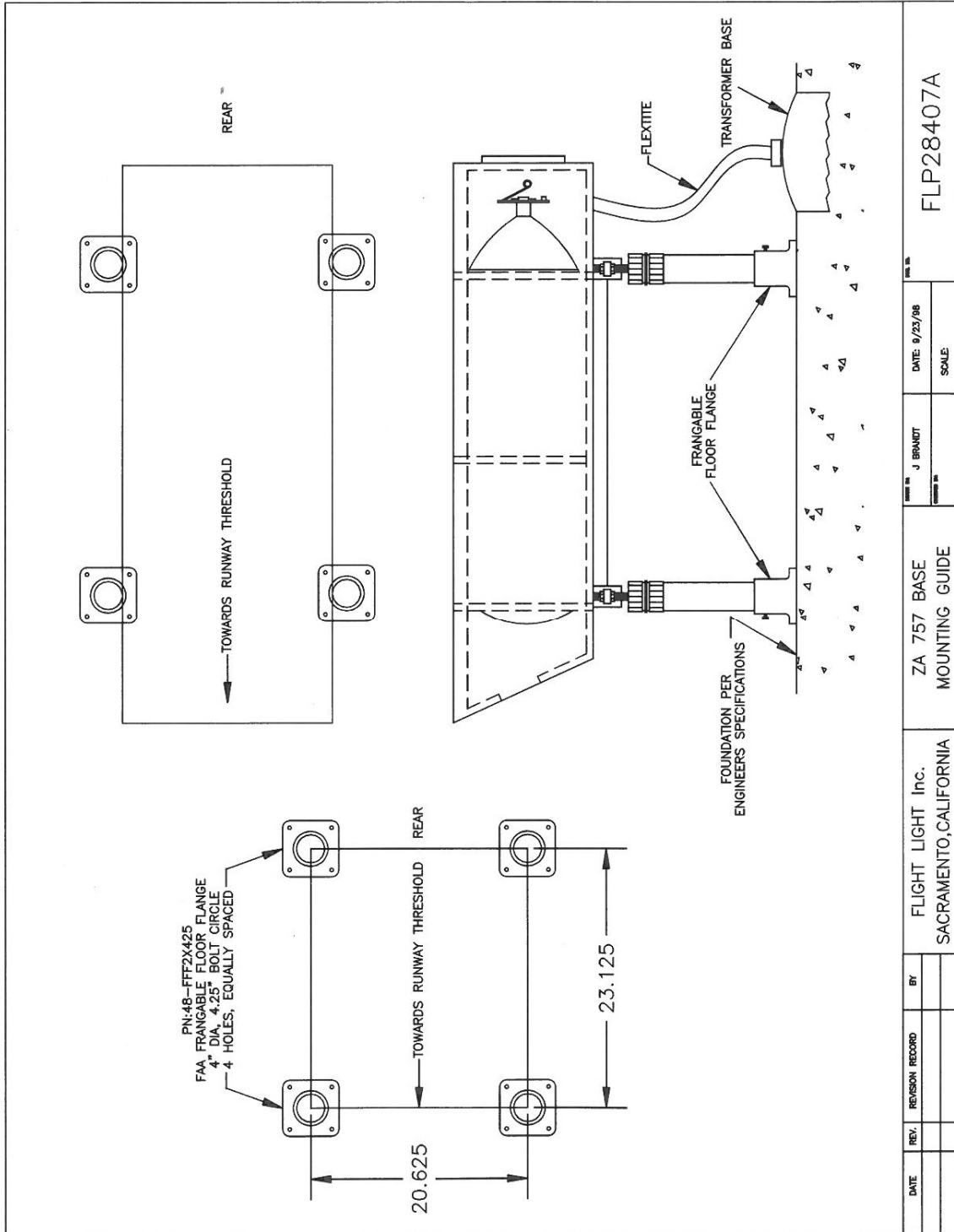

**Figure 5 – Base Mounting Guide**

DATE		REV.		REVISION RECORD		BY		FLIGHT LIGHT Inc. SACRAMENTO, CALIFORNIA		ZA 757 BASE MOUNTING GUIDE		J. BRANDT		DATE: 9/23/98		SCALE		FLP28407A	

### 3.1.2 Installation and Mounting of the Controller

The Controller may be mounted to a pole or a wall depending on your location.

For pole-mounting:

- Vertical channel may be lagged directly to a pole or attached using optional stainless steel straps.
- The straps are rated for 450 lbs each and can be used for pole diameters from 4" up to 10".
- The horizontal rails include all hardware needed to secure the enclosure to the rails.

For wall-mounting:

- Secure the enclosure to wall studs or another sturdy anchoring medium using ¼" bolts via mounting holes at top and bottom.

### 3.1.3 Interconnect Wiring

Only five wires are needed between the Controller and the two LHA's. A Wiring Diagram for the LED Lamps in the Light Housing Assembly is presented below in Figure 6. The CTRL or dimming signal is an analog voltage between 1 and 5 VDC which controls the output light intensity.

The Tilt Switch wiring connections are shown in Figure 6 below. The circuit is a basic series circuit, at +12VDC. If there is continuity through the Tilt Switches the lights will remain on. If either one of the Tilt Switches is opened up for longer than 10 seconds, +12VDC will not be present at the return terminal. The Controller will detect this condition and turn the all lights off until the tilt condition is removed.

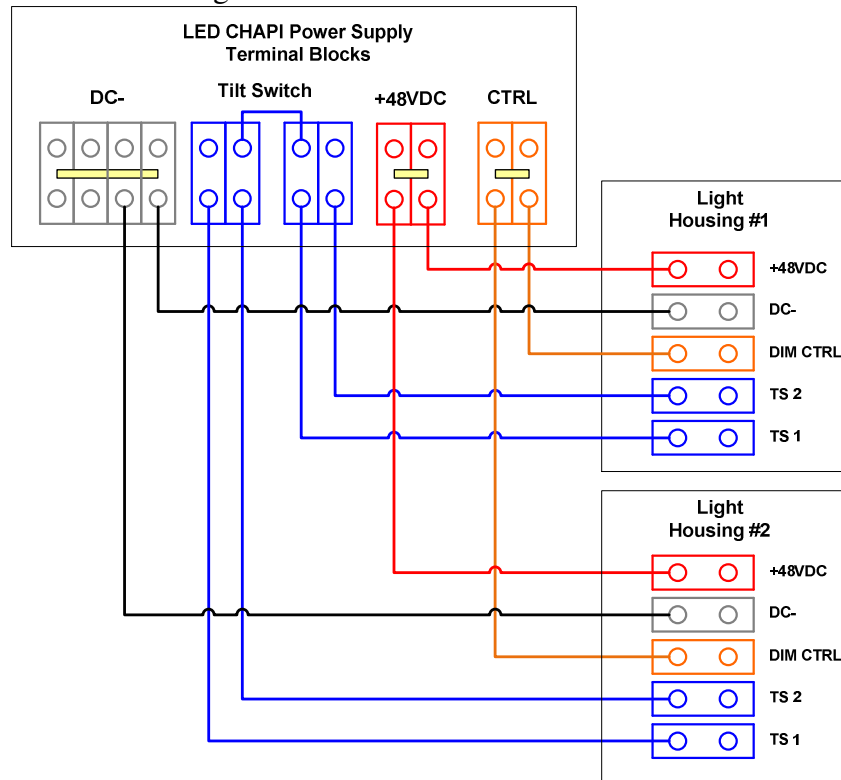

Figure 6 – Wiring Diagram

### 3.1.4 Input Power Wiring

Your CHAPI Controller requires 48VDC input power to operate properly. A high-quality Surge Suppressor is included to clamp transient voltages from damaging the power supply.

### 3.1.5 Photocell Wiring

Wire/connect the photocell to the terminal block located in the top left of the controller/power adapter. Match the color of the photocell wires to the color of the terminal block. Red wire to red terminal block, repeat with the other two colors.

Photocell Wiring	
Wire Color/Terminal Block Color	Terminal
RED	LOAD
WHITE	-
BLACK	+

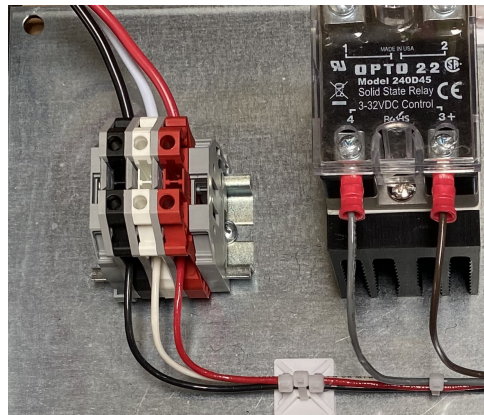

### 3.1.6 Night Mode Dimming

Your CHAPI Controller will have the light output dimmed during night mode. With the photocell connected to the Controller box and at night/dark conditions, the photocell will automatically dim the light output to approximately 50% intensity.

### 3.1.7 Alignment of the Light Housing Assemblies

The Aiming Device consists of precision machined aluminum blocks corresponding to the particular angles required by Glide Slope and number of boxes. There are 5 blocks for a four box system and 3 blocks for a two box system with standard CHAPI Glide Slope Angle of 6 degrees. Non standard Glide Slopes will require special sets of aiming blocks.

The Aiming Blocks are designed to be set on the edge of the light box with the provided spirit level on the top surface. Refer to Fig. 8



**Figure 8 - Aiming Device positioning.**

The Light Housing Assembly nearest the helipad should be adjusted to the (6° typical) Glide Slope Angle + 1/4° (+15 minutes). The light box assembly farthest from the helipad should be adjusted to the Glide Slope Angle - 1/4° (-15 minutes). When the LHA's are in place, make sure both are adjusted with the leg adjustment jacks so that the center of the LHA lenses are at the same elevation. Remove the cover from the Light Housing Assembly.

For horizontal alignment place the 6" level across the light box, either on the lens housing or reflector housing. Adjust the forward nuts on the leg adjustment jacks to bring the level to center.

For each 1/4 turn executed on the nut on one side, turn the nut on the other side 1/4 turn in the opposite direction. This will keep the lens center at the same elevation at all times during adjustment. Recheck both points. Position the proper aiming block on the edge of the light box for vertical alignment. Place the level on the aiming block. Adjust the both rear adjustment jacks to bring the level to center. Next, tighten the bolts holding the pivots. These are accessible underneath the unit at the forward corners.

Recheck the horizontal adjustment at points at each corner and adjust as required. Tighten all nuts securely. Recheck the vertical adjustment and tighten all nuts on the new pivot. Last, place the level on top of the tilt switch. Adjust the tilt switch until the level is centered. Tighten the bolts to hold the tilt switch secure. Replace the cover on the Light Housing Assembly.

### 3.1.8 Flight Testing

Before placing in service, the system should be thoroughly flight tested. The flight test should include flying over any and all obstructions in the approach area to be sure that all light boxes show red whenever you are close to the obstructions. Several normal approaches should be made to insure good signal presentation at all typical points in the approach path.

### 4.0 Maintenance and Troubleshooting

If further assistance is required please call Flight Light Technical Support for assistance or Sales to order replacement parts at (916) 394-2800.

<b>Problem</b>	<b>Possible Cause</b>	<b>Test</b>	<b>Remedy</b>
All lights are not ON	1. Tilt switch has created an open circuit.	1a. Power OFF: Check for resistance ( $R < 10\Omega$ ) between TS Out and TS In terminals on Controller. b. Power ON: Verify about 12VDC is measured between the TS In and DC- terminals on the Controller.	1a. Low resistance ( $R < 10\Omega$ ) indicates Tilt Switches are GOOD. b. If approximately 12VDC is present at TS In there is no tilt condition. c. If either (a) or (b) fails a tilt condition exists. Replace the Tilt Switches or the Controller Circuit Board.
	2. Failed power supply.	2a. Verify +12VDC between red (+12VDC) and gray (DC-) terminal blocks. b. Verify +48VDC between the red (+48VDC) and gray (DC-) terminal blocks.	2a. Replace 12 volt power supply.  b. Replace 48 volt power supply.
	3. Source power not available.	3. Verify 48VDC is present between #2 terminal (+) and #4 terminal (-) on the Circuit Breaker.	3. Check power at your location.

Some lights are out	1. An LED Board in an LHA has failed.	1. Verify input voltages to LHA: a. +48VDC (red wire) to DC- (black wire). b. +1 to +3VDC at Dimming input to LED Driver board in LHA (brown wire). c. Verify +1 to +3VDC at CTRL output of Controller.	1a. If voltage is not present see step 2b above.  b. If dimming voltage is not present check wiring between Controller and LHA.  c. If voltage is not present replace the Controller Circuit Board. d. Otherwise, replace failed LED Board.
Light output never changes brightness levels	1. Photocell is bad.	1a. Verify +12VDC input voltage at red Photocell terminal block.  b. Verify day/night switching at Photocell output (orange terminal block at top of Controller): DAY = +12 VDC NIGHT = 0 VDC	1a. If +12VDC is not present check power supply output. Consider replacing +12DC power supply if AC input voltage is present.  b. If day/night switching voltages are not observed replace Photocell.

## 5. Warranty

Your Flight Light Incorporated (FLI) LED CHAPI has been built and tested according to a strict Quality Assurance policy meeting ISO9001-2015 standards. FLI provides a 5-year limited system warranty on the LED CHAPI product purchased and assembled from FLI. The LED CHAPI product is defined to contain the Controller and two Light Housing Assemblies. An LED CHAPI product suitable for warranty coverage must have been sold with a FLI Sales Order. The date of shipment from FLI shall designate the Start Date of the 5-year period. The warranty Start Date shall not commence with the product installation date.

Any system components which are integrated into the system, but not built and assembled by FLI are excluded from the 5-year warranty. FLI does not warranty the workmanship of the installer or any damage caused by product shipment, improper maintenance, vandalism or acts of nature. It is strongly recommended to have a licensed engineer approve the installation of the LED CHAPI product.