

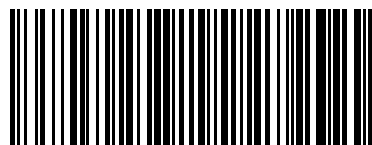

L860 Elevated Incandescent Light



Revision A 8/25/2017

Flight Light Inc.

2708 47th Avenue

Sacramento, CA 95822

www.flightlight.com

Ph: 916-394-2800



FL-860 Elevated Incandescent Perimeter Light User Instructions

Your Flight Light FL-860 light fixture has been designed to provide years of service, please follow the recommendations outlined in this guide.

Contents

A. Safety Measures.....	2
B. Installation	3
1. Base Can Installation.....	4
For Existing Pavements:.....	5
For new installations:.....	8
2. Soil- Stake Installation.....	10
3. Low Surface Mount Installation.....	11
C. Wiring.....	12
D. Limited Warranty	14



A. Safety Measures

You must know whether your heliport lighting system is powered by AC or DC before installing the fixture. AC models work on either 120VAC or 240VAC if Halogen or Incandescent. The lights are designed to be installed in a parallel circuit, which maintains a constant voltage and brightness for all lights.

Ensure power is off before installing or servicing heliport fixtures!

Follow the local NEC code!

Make sure the equipment is rated and approved for the environment in which you are intending to use it. Do not operate this equipment in humid, flammable, or explosive environments unless it has been rated for safe operation in these environments.

Use only electrical wire of sufficient gauge and insulation to handle the rated current and voltage demand.

Route electrical wiring along a protected path. Make sure they will not be damaged by moving equipment.

Protect components from harsh environment conditions.

Protect equipment with safety devices as specified by applicable safety regulations.

Before starting this equipment, check all safety interlocks, fire –detection systems, and protective devices such as panels and covers. Make sure all devices are fully functional. Do not operate the system if these devices are not working properly.

Never operate equipment with a known malfunction.

Do not attempt to operate or service electrical equipment if standing water is present.

Do not touch exposed electrical connections on equipment while the power is ON!



B. Installation

Each light is packed in its own box 18" x 12" x 12". Carefully remove the light from its box and inspect for damages. If any damages are found, file a claim with the carrier.

There are three wires at the bottom of the fixture for you to connect inside the base can. Consult your local electrical codes or inspector for the proper wire to use (which should take local temperature effects into account), AWG14 is adequate for most locations according to NEC 2014.

- Black (AC Line)
- White (AC Neutral)
- Green (Ground)

The following picture shows the FL-L860 Perimeter Light:





1. Base Can Installation

There is no standard way to build a helipad. Each project includes its own individual variables. Some of these are:

- The type of paving material to use
- Anticipated loads and traffic
- The kind of subsoil
- The kind of subbase to use
- The need for special treatment of the subsoil
- Water conditions at the site
- Other environmental conditions
- The need for concurrent operations during construction
- Funds available

Only the consultant familiar with all the variables of a given site can properly design the project. Once the specific design is produce appropriate methods can be followed to successfully install the lighting system.

The purpose of the following procedure is to provide installers with guidance on how to install the base cans.

The base cans comes with the following accessories:



- Plywood cover 8" Diameter 1/4" Thick
- 6 x Bolts
- Gasket
- 2 x Grommets
- 2 x PVC Fittings for the drain hole

The plywood cover imitates the thickness of the base plate.

1. The base cans comes with the cover installed and the accessories inside. Remove the cover and get the accessories out. Place the plywood cover back on the base can for concrete pouring.



For Existing Pavements:

2. To install base cans, begin by core drilling (typically 12"-14" in diameter, the depth will be per the terrain and/or suggestion of the civil engineer/contractor) holes in the locations specified by the project engineer. Saw cuts should then be made to allow room for the fixture power cables (typically 3" deep x 1/2" wide). Saw cuts are typically made in line with the centers of the conduit holes.
3. Prepare the drainage system specified by the design engineer. (see figure 1 on page 7 and notes)
4. Install the rubber grommets in each of the side holes.



5. Install the base can drain fittings provided (pictured below) into each base can drain hole. Run 1-1/2" size pipe, schedule 40 PVC, into the fittings of the base can. Pipe length should be cut so the pipe, when positioned over the drain, extends approximately 3" to 4" into the drain rock.



External Fitting (Left) and Internal Fitting (Right)



Base Can with fitting installed

6. Use of mounting jig is recommended for proper alignment of base cans. First, place the plywood cover on the base can, and then mount the mounting jig to the base can with the two bolts that fit into the base can bolt holes.



7. After the mounting jig is attached, suspend the base can so the top of the plywood cover is flush with the surface of the pavement.
8. The gasket provided with the base plate needs to be installed in between the plate and the can. An allotment between .125" and .250" beneath the grade for the gasket and the light fixture base will provide flush or slightly above grade mounting, which will promote water flow away from the fixture.
9. After the base cans are installed, test the drainage system by pouring water into the installed base can at each fixture location. Pour enough water to verify that the underlying ground is absorbing the water. If the base can is not draining properly, modifications to the drainage system will be necessary. In this case, consult with your project engineer before proceeding.
10. FAILING TO HAVE PROPER DRAINAGE WILL DAMAGE THE LIGHT. FLIGHT LIGHT INC WILL NOT COVER SUCH WATER DAMAGES UNDER WARRANTY.
11. Once satisfied with drainage system, move on to the installation of the fixture power cables.
12. Run fixture power cables to each base can, one black wire, one white wire, and one green wire (grounding). Thread the light into the base plate and wire the cables coming from the light to the incoming power cable.
13. Mount the base plate over the base can. Secure it with the 6 bolts received.



Figure 1: Base Can Installation – Core Drill and Saw Cut

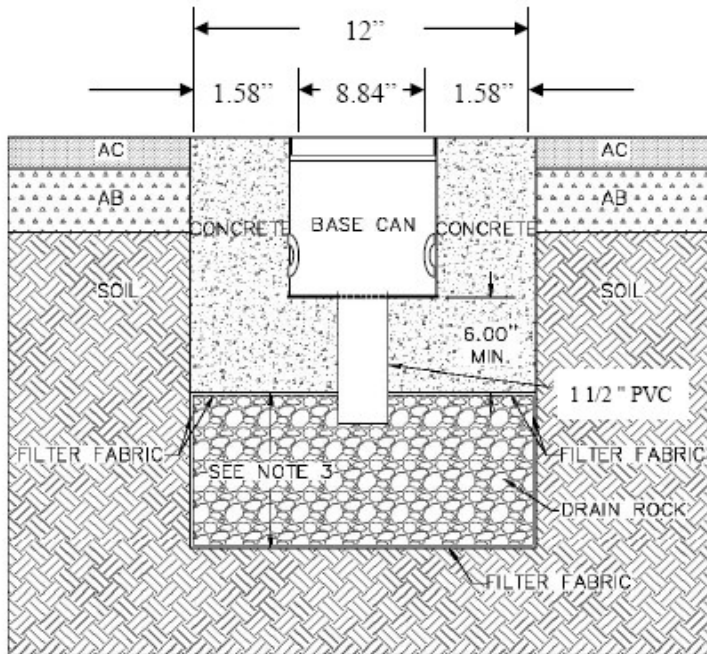

Notes:

1. Drain rock shall be graded from 1 inch to ¼ inch.
2. Drain rock shall be encased in a filter fabric material to avoid soil infiltration into the drain rock.
3. Recommended depth of drain rock unit varies dependent upon the type of existing soils.
 - a. Where existing soils are granular and permeable the depth of the drain rock unit can be limited to 1 foot.
 - b. Where existing soils are fine graded and have low permeability the depth of the drain rock unit should be increased to 3 feet or greater to provide a reservoir for short term retention. Refer to engineering plans for the requirements specified by the project engineer.
4. Concrete shall be 3/8 inch maximum aggregate mix, use a minimum of seven sacks of cement per cubic yard of concrete and poured from a height of approximately 5 inches above the can. Concrete should only be poured from one side. Vibrate or rod concrete to completely fill the area below and on all sides of the base can. When concrete is visible on the side opposite to the side that concrete is being poured from, pouring can commence from alternate locations.
5. Abbreviations: Asphalt Concrete (AC), Aggregate Base (AB).



For new installations:

For a completely new helipad, before pouring the concrete, create the appropriate drainage system. See Figure 1 on page 7 and notes.

1. Install the rubber grommets in each of the side holes.



2. Install the base can drain fittings provided (pictured below) into each base can drain hole. Run 1-1/2" size pipe, schedule 40 PVC, into the fittings of the base can. Pipe length should be cut so the pipe, when positioned over the drain, extends approximately 3" to 4" into the drain rock.





3. The gasket provided with the base plate needs to be installed in between the plate and the can. An allotment between .125" and .250" beneath the grade for the gasket and the light fixture base will provide flush or slightly above grade mounting, which will promote water flow away from the fixture.
4. After the base cans are installed, test the drainage system by pouring water into the installed base can at each fixture location. Pour enough water to verify that the underlying ground is absorbing the water. If the base can is not draining properly, modifications to the drainage system will be necessary. In this case, consult with your project engineer before proceeding.
FAILING TO HAVE PROPER DRAINAGE WILL DAMAGE THE LIGHT. FLIGHT LIGHT INC WILL NOT COVER SUCH WATER DAMAGES UNDER WARRANTY.
5. Once satisfied with drainage system, move on to the installation of the fixture power cables.
6. Run fixture power cables to each base can, one black wire, one white wire, and one green wire (grounding). Thread the light into the base plate and wire the cables coming from the light to the incoming power cable.
7. Mount the base plate over the base can. Secure it with the 6 bolts received.





2. Soil- Stake Installation



L895

Mounting Stake galvanized to ASTM-A123/A123M-02

Shipped with:

- 1 x 2 hole cable clamp and
- 2 x #10-24 x 1 3/4" SS machine screws

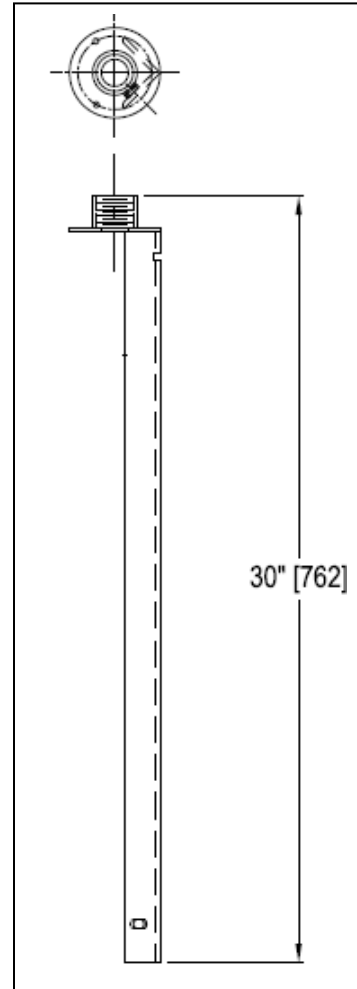

1. Thread the coupling of the light into the mounting stake and run fixture power cables to each light, one black wire, one white wire, and one green wire (grounding) to each can.
2. Follow the wiring instructions on the next page.
3. Install the stake in a 6-inch (15 cm) diameter hole at a depth of 30 inches (76 cm). Do not install stake by driving.
4. Make electrical connections and backfill around the stake with thoroughly compacted earth passing a 1 inch (2.54 cm) sieve.
5. Where required due to unstable soil conditions, backfill with concrete. Install the top of the stake even with, or not more than 1/2-inch (1.3 cm), above the finished grade and maintain within 1 degree of the vertical.
6. In areas where frost may cause heaving, anchor the stake with concrete and use a permeable backfill material such as sand around the buried electrical components and then cover the top surface with an impervious material to reduce moisture penetration.



3. Low Surface Mount Installation

1. Mount box to surface.
2. Install fittings or conduit using sealing compound on threads.
3. Pull supply wires into box.
4. Thread the light into the cover and run the wires through the top hole and through the gasket. See picture below. Connect/Splice them to the incoming power cables.



5. Attach system ground wire under head of green screw in box.
6. Center cover gasket evenly. Locate pre-perforated holes in the gasket and install the gasket so they align with the mounting holes in the box. Install cover with the two screws provided.
7. Use caulking around cover.
8. Cover the conduits that are not used with the plugs provided.





C. Wiring

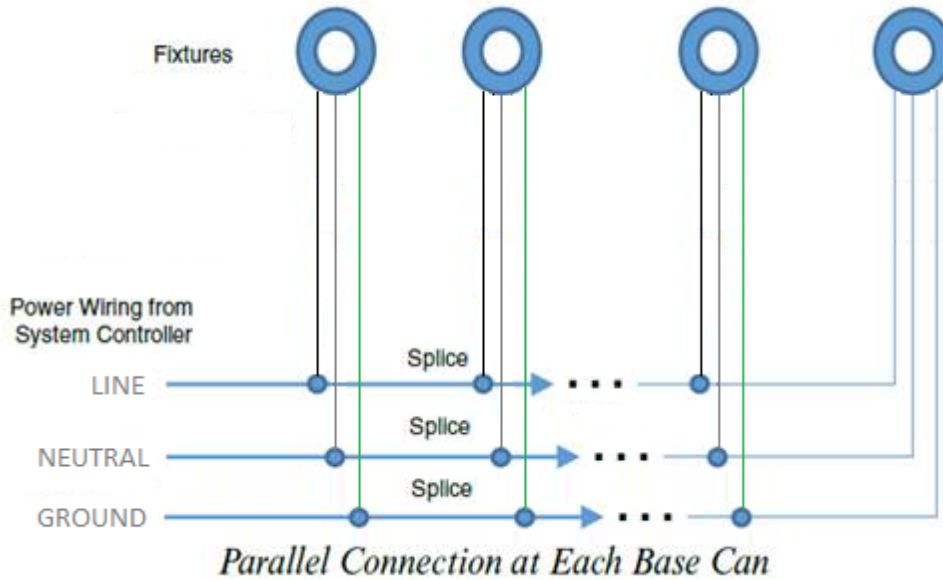

The installation of lights is recommended to be done in a parallel circuit in a secure, waterproof junction box. Junction boxes are not provided with the lights.

The gauge of the electrical wire is to be calculated by the electrical engineer and should be sufficient to handle the rated current and voltage demand.

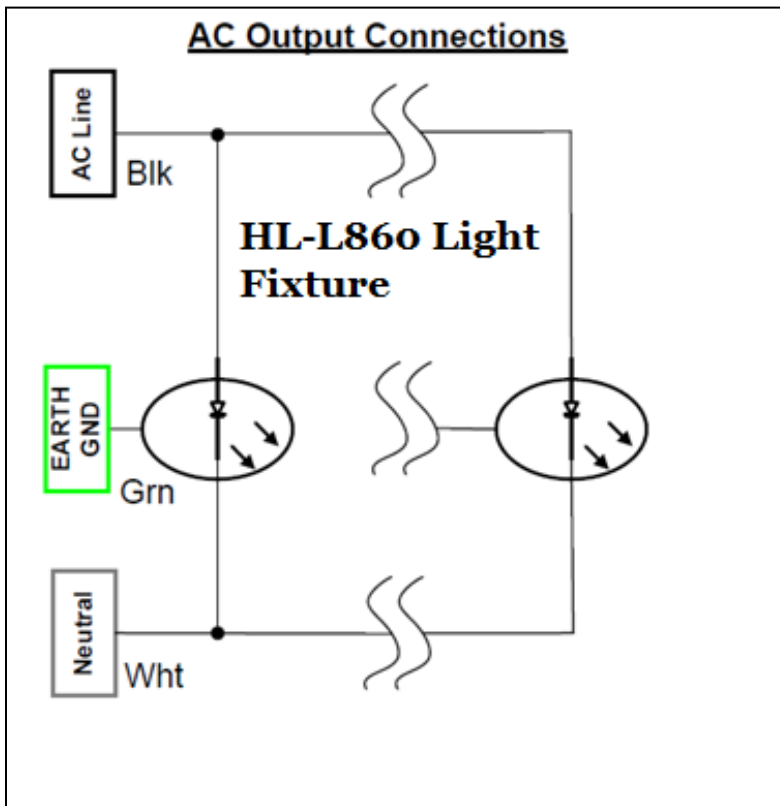
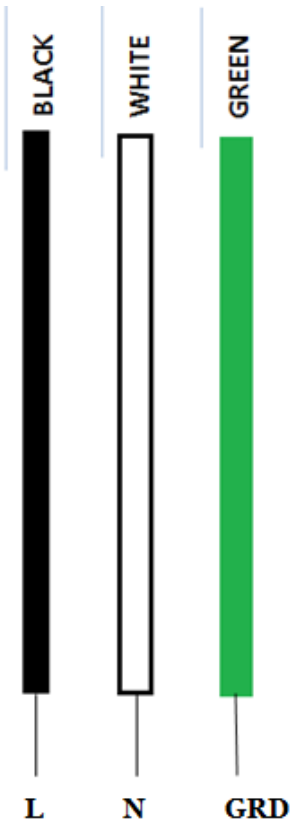



D. Limited Warranty

Duration of the Warranty: Flight Light Inc. warrants all of the goods which it has manufactured to be free of material defects for the following durations.

Lamps: For a period of 90 days from the date of shipment to Buyer. Product liability is limited to lamp replacement and does not include incidental labor.

FAA products: For a period of one year from the date of installation or two years from the date of shipment to Buyer.

LED Light Fixtures: For a period of 2 years from the date of shipment to Buyer. Complete Systems: Systems including at least one Flight Light Inc. Controller and one Flight Light Inc. LED Light Fixture, for a period of 5 years from the date of shipment to Buyer.

Buyer's Remedies: If any such goods are found to be materially defective within the warranty period, Flight Light Inc. agrees to attempt to repair, and if unable to repair, to replace the defective goods without charge to Buyer.

Buyer's remedy with respect to such goods is limited to repair or replacement. For goods not manufactured by FLI, Buyer agrees to accept as its sole remedy the warranty, if any, offered by the manufacturer or manufacturers of such goods. FLI makes no warranties, express or implied, other than those stated in this paragraph.

Warranty Exclusions: Flight Light Inc. shall not be liable under this warranty if any of the following conditions apply:

- 1) Unauthorized personnel attempt any repairs to Flight Light Inc. products without Flight Light Inc. consent.
- 2) Products are damaged by natural phenomenon, misuse, abuse, accident, alteration, or incorrect electrical current or voltage.
- 3) Products are improperly installed, or damaged in shipping.

Warranty Limitations

FLI makes no warranties, express or implied, other than those stated herein. FLI does not warranty the workmanship of the installer, damage caused by acts of nature, vandalism, improper installation, or damage caused by improper maintenance. The warranty period of LED fixtures covered under the 5-year system warranty is reduced to two years when fixtures are subjected to abrasive materials or chemicals. FLI reserves the right to either repair or replace any defective component covered under the terms of any of its warranties. FLI is not an engineering firm and makes no expressed or implied warranty as to the applicability of its products or systems in any specific situation, application or location: such decisions are the responsibility of the owner, design engineer and/ or others. Therefore, as to all goods sold by FLI, FLI hereby disclaims any implied warranty of merchantability or implied warranty of fitness for a particular purpose and Buyer agrees that FLI shall not be liable for any special, indirect, incidental, consequential or liquidated damages of any kind, whether the Buyer's or any other claim is based upon contract, tort or any other legal theory.