



Flight Light Inc.  
2708 47th Ave.  
Sacramento, California, U.S.A.  
95822-3806

PH (916) 394-2800    FX (916) 394-2809  
TF (800) 806-3548    EM sales@flightlight.com

## HL-392 LED or Halogen 8" Helipad Semi-Flush Perimeter Inset Light

- Compliances**
- FAA AC 150/5390-2D Heliport Design Guide
  - Exceeds FAA AC 150/5390-2D Appendix G Specifications
  - ICAO Annex 14, Volume II for TLOF
  - UL 1598 Standard (only "LPUL" lamp is UL listed)
  - Transport Canada TP14371, AGA 7.16
  - IP67 Compliant
  - Buy American Act Compliant

### Applications

Semi-flush perimeter light helps mark helipad touchdown and lift-off area (TLOF) and/or final approach and take-off area (FATO) for pavement heliports.

### Why Our HL-392 is Better

- Recessed, semi-flush mounted, allows for obstruction-free movement of equipment and personnel.
- Lightweight and robust aluminum alloy construction.
- Hard anodized for increased wear and corrosion resistance.
- Pressure test plug ensures moisture-proof light cavity.
- Prism removal and replacement achieved without need for adhesives or sealants.
- Pre-focused optics simplify maintenance.
- Available in 10-30VDC, 120-240VAC or 277VAC versions.
- Direct retrofit, drop in replacement. Factory retrofits available for your existing halogen fixtures.
- Independent intensity testing has provided results which exceed FAA AC 150/5390-2D Appendix G specifications.
- Available for non-heliport applications such as architectural lighting.

### Specifications

- Anodization: Aluminum fixtures, machined stock 6061T6. Hard Anodized MIL 8625 Type III, 1 mil thick; Class 1 for clear, Class 2 for color.
- Hardware shall be 304 stainless steel.
- Low profile: .81" [2.06 cm] (base can mounted), 1.06" [2.69 cm] (helideck mounted).
- Diameter: 8" [20.32 cm]
- Bolt circle: 7.25" [18.42 cm]

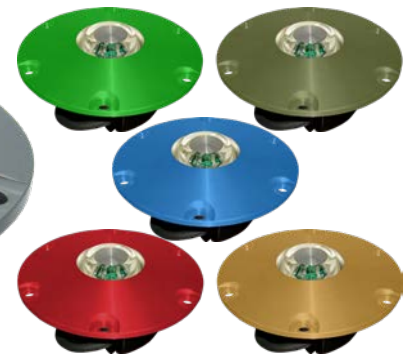

*Custom color matching is available to meet your design specifications.*

- Light channel within .2" (.5 cm) of grade.
- Color beam variations achieved by dichroic coating.
- Fixture grounding: internal.
- Includes 48" [122 cm] of UL SO Cable 16AWG (UL Version).
- Weight: 4.65 lb. (2.1 kg). Carton size: .23 cu. ft. (.007 cu. meters); 9" (d) x 9" (w) x 5" (h) (22.86 cm (w) x 22.86 cm (d) x 12.7 cm (h))
- Temperature range: -4°F/+131°F (-20°C/+55°C).

### LED Version

- Cost-saving, energy-efficient LEDs.
- Power Consumption: AC input = 7.2VA; DC input = 4W; IR AC input = 10.8VA; IR DC input = 7.2W
- Power adapter included.
- Low maintenance - LED light source has 50,000 hour lifetime (50X longer than halogen).
- Monochromatic output of LEDs is more conspicuous than halogen.
- Pilots prefer LED over halogen because of increased visibility.
- With our Dimming Controller option, the lights can be dimmed at night to reduce glare - 3 brightness levels.

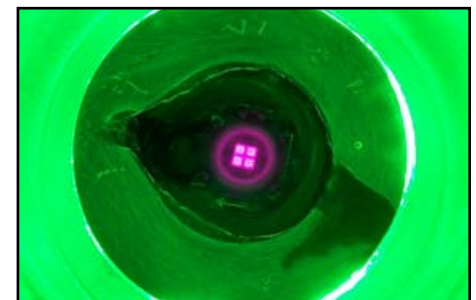

### Visible/Infrared LED Option

- Night Vision Goggle (NVG) compatible.
- Infrared Output:
  - Exceeds SAE Aerospace recommendations for Landing/Taxi Lights.
  - Usable beam width: 55° to 125° vertical, 360° horizontal.
  - Output wavelength: 850nm.
  - Infrared does not dim with the "LVD" dimming option.
- Visible Output:
  - Exceeds ICAO TLOF requirements for green LEDs (see photometric chart).
  - Usable beam width: 30° vertical, 360° horizontal.
  - Output wavelength: 530nm.

**Visit our web site: [www.flightlight.com](http://www.flightlight.com)**



**Flight Light Inc.**  
 2708 47th Ave.  
 Sacramento, California, U.S.A.  
 95822-3806

**PH (916) 394-2800**    **FX (916) 394-2809**  
**TF (800) 806-3548**    **EM sales@flightlight.com**

**HL-392**  
**LED or Halogen**  
**8" Helipad Semi-Flush**  
**Perimeter Inset Light**

**Common Replacement Parts (Halogen & LED)**

- 1..... Body Casting (Std) – Anodized
- 2..... Deep Bottom Cover Casting.....80-040206
- 4..... Bottom Cover Gasket.....27-4061T271
- 6..... Prism Clamp .....36-392-PLT
- 15..... Prism Clamp Gasket .....80-021309
- 16..... Prism Gasket .....65-033090
- 18..... White (Clear) Prism Dome .....20-016080
- 25..... Pressure Test Plug.....80-021256
- ALT ... Schrader Tank Valve .....80-021327
- 27..... 2-Pin Male Connector .....TRC-10518-117D002
- 28..... 3-Pin Male Connector (DC Dimming only)..80-013031
- 29..... 2-Conductor Female Connector.....TRC-10519-07-021
- 30..... 3-Conductor Female Connector (DC Dimming only)..80-012022

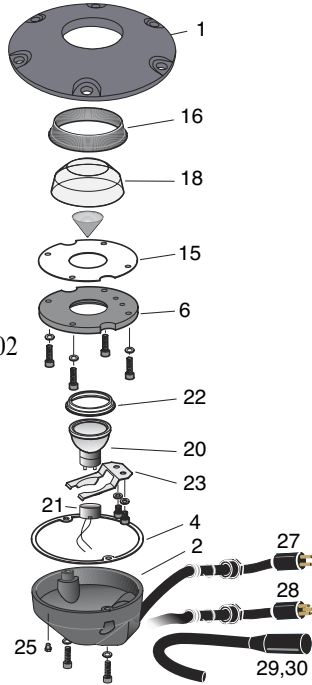

**Halogen ONLY Parts:**

- 18..... Green Prism Dome.....80-019193
- ALT ... Yellow Prism Dome.....80-019191
- ALT ... Red Prism Dome .....80-019182
- ALT ... Blue Prism Dome .....80-019190
- 20..... 50W 120V Reflector Lamp .....LA-008084
- 21..... 120V/240V Lamp Holder .....80-015057
- 22..... Lamp Gasket.....80-033077
- 23..... Lamp Retaining Spring .....80-032039

**LED ONLY Parts:**

- 26A .... AC LED Replacement Kit .....HL-XL8KITB-AC\*
- ALT ... Dimming LED Replacement Kit....HL-XL8KITB-D\*
- ALT ... DC LED Replacement Kit .....HL-XL8KITB-DC\*
- ALT ... UL LED Replacement Kit .....HL-XL8KITB-UL\*
- 26B .... Halogen to LED Retrofit Kit .....HL-XLPKITB-392\*

\* For LED Replacement Kit, X = Color

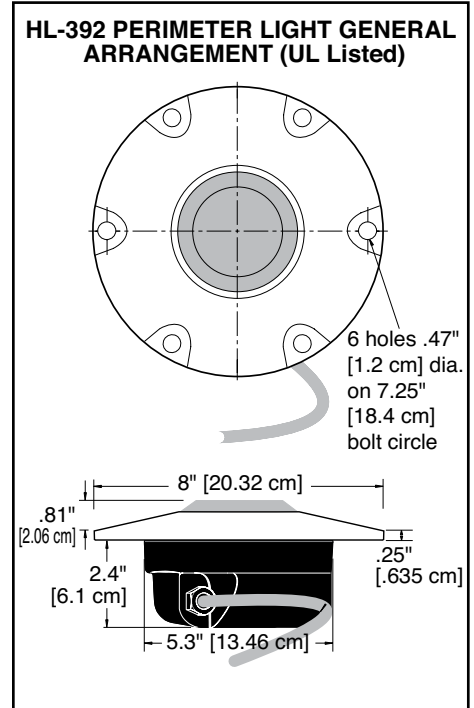
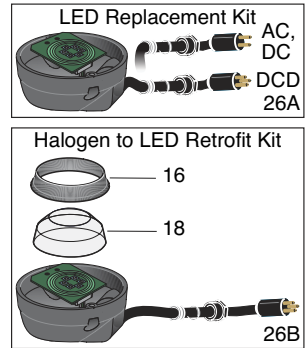

**Photometric Comparison with ICAO Requirements for TLOF**

Vertical Angle (Deg)	Avg. Intensity (Cd)	ICAO Spec (Cd)
2	70.8	15
5	66.5	30
10	48.3	15
13	36.6	8
20	23.9	3

**Ordering Codes**

Fixture	Output	Power/Compliance	Custom Color <sup>5</sup>
<b>HL-392</b>	<b>G:</b> Green (std) <sup>1</sup> <b>B:</b> Blue <b>R:</b> Red <b>W:</b> White <b>Y:</b> Yellow <b>IR:</b> Infrared <sup>2</sup>	<b>50:</b> 50W, 120V <sup>3</sup> <b>52:</b> 50W, 240V <sup>3</sup> <b>LP:</b> 120-240VAC LED <sup>3,4</sup> <b>LP3:</b> 277VAC LED <sup>3,4</sup> <b>LPUL:</b> 120-240VAC LED <sup>4,6</sup> <b>LV:</b> 10-30VDC LED <sup>3,4</sup> <b>LVD:</b> Dimming 10-30VDC LED <sup>3,4</sup>	<b>G:</b> Green <b>B:</b> Blue <b>MG:</b> Military Green <b>R:</b> Red <b>Y:</b> Yellow (hard gold)

<sup>1</sup> Green is currently the recommended output color for heliport perimeter lights.  
<sup>2</sup> Infrared must be used in conjunction with visible LEDs. Infrared does not dim with the "LVD" dimming option.  
<sup>3</sup> Lamp option is not UL listed.  
<sup>4</sup> Color LED with white (clear) prism. Power adapter included.

<sup>5</sup> Gray anodized is the standard finish.  
<sup>6</sup> Only "LPUL" lamp option can be UL listed. Connector not included. UL labeled fixtures only available for shipment to U.S. and Canada.

**Visit our web site: [www.flightlight.com](http://www.flightlight.com)**



Flight Light Inc.  
2708 47th Ave.  
Sacramento, California, U.S.A.  
95822-3806

PH (916) 394-2800    FX (916) 394-2809  
TF (800) 806-3548    EM sales@flightlight.com

**HL-392**  
**LED or Halogen**  
**8" Helipad Semi-Flush**  
**Perimeter Inset Light**

### How to Specify the HL-392 Helipad Semi-Flush Perimeter Light

The fixture shall be model HL-392-(LED color)-(lamp type and voltage) as marked by Flight Light Inc.

#### Construction:

- The fixture shall be 8" [20.32 cm] diameter, 7.25" [18.42 cm] bolt circle.
- Casting thickness shall not exceed .25" [.64 cm].
- The fixture shall be omnidirectional.
- The fixture shall be aluminum, anodized (Type III).
- The fixture shall have a modular design comprised of 2 major parts: Bottom Casting and Top Casting. The Bottom and Top Casting are sealed by means of a Prism Clamp and O-ring.
- Hardware shall be 304 stainless steel.
- Fixture shall ground internally.
- The fixture shall include 48" [122 cm] of UL SO Cable 16AWG (UL Version).

#### LED/Light Cavity:

- LED lifetime expectancy: 50,000 hours.
- Power consumption shall not exceed 7.2VA for AC lights, 4W for DC lights, 10.8VA for IR AC lights and 7.2W for IR DC lights.
- Infrared output wavelength: 850nm
- Infrared output usable beam width: 55° to 125° vertical, 360° horizontal
- Visible output wavelength: 530nm
- Visible output beam width: 30° vertical, 360° horizontal

#### Compliances:

- IP67 Compliant
- Buy American Act Compliant
- FAA AC 150/5390-2D Heliport Design Guide
- ICAO Annex 14, Volume II for TLOF
- Optical performance exceeds FAA AC 150/5390-2D Appendix G Specifications
- Transport Canada TP14371, AGA 7.16

#### Options (to be specified per each project):

- Infrared (must be used in conjunction with visible LEDs)
- Dimming (only available with the Flight Light controller)
- UL Listed fixture
- Fixture Custom Color (default color is grey)

**Visit our web site: [www.flightlight.com](http://www.flightlight.com)**



Flight Light Inc.  
 2708 47th Ave.  
 Sacramento, California, U.S.A.  
 95822-3806

PH (916) 394-2800  
 TF (800) 806-3548

FX (916) 394-2809  
 EM sales@flightlight.com

**HL-392**  
**LED or Halogen**  
**8" Helipad Semi-Flush**  
**Perimeter Inset Light**

**5" Shallow Base (P/N BA-725-5-2P1)**  
 • L-868A FAA Approved

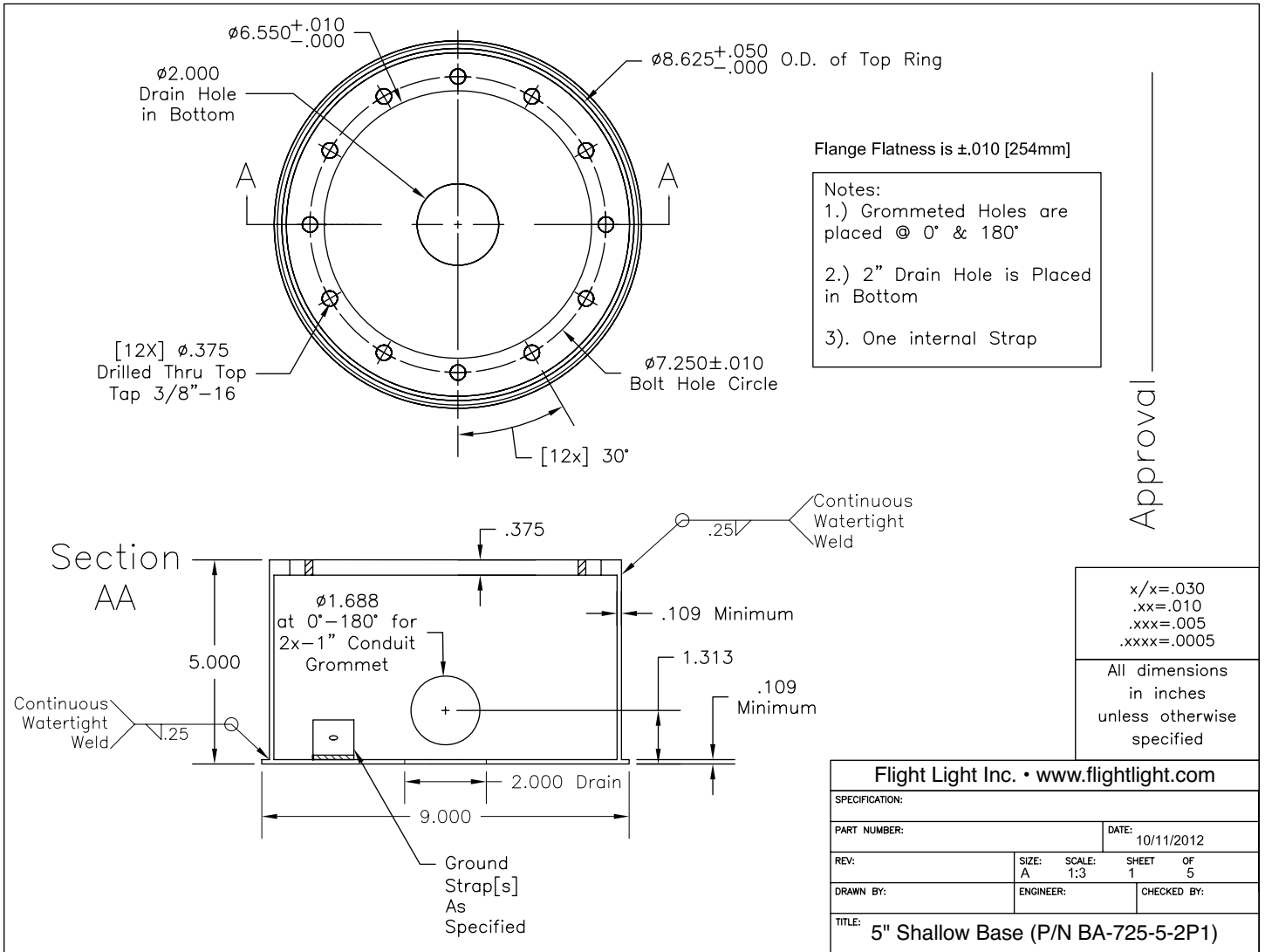

Approval

Visit our web site: [www.flightlight.com](http://www.flightlight.com)