



Heliport 120VAC Controller with Photocell Installation Instructions

HL-HSC-AC1ACP

Your Heliport Controller has been designed with safety and protection features to provide years of service with minimum maintenance when used properly. Please follow these instructions for proper installation and operation. The photocell is protected from lightning and other transients by a high quality Surge Arrestor. The photocell switches the load on during nighttime conditions; a Circuit Breaker restricts the load current to 20A maximum (per NEC you should not have more than 16A to the load).

CAUTION! This system may have high voltages and currents while it is operating, it is recommended to use high voltage gloves whenever the circuit breaker is ON.

Installation Mounting Instructions

- When selecting a mounting location the Photocell sensor window must be facing North (there is an "N" on the top of the Photocell) since direct sunlight is not recommended. The enclosure mounting location should not be close to a heat source.



Enclosure Showing Mounting Tabs

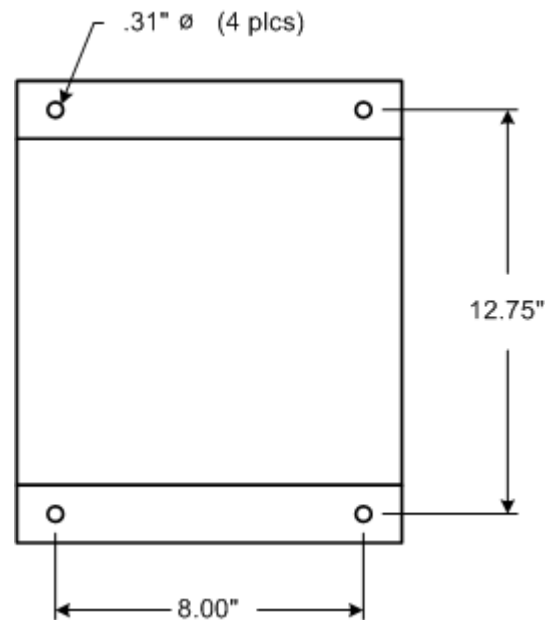

Mounting Layout

- The controller enclosure is NEMA 4 compliant, and is usually mounted to a wall utilizing the four mounting holes located on the enclosure's mounting tabs (mounting hardware supplied by



Heliport 120VAC Controller with Photocell Installation Instructions

HL-HSC-AC1ACP

installer). The overall dimensions of the enclosure body are 12”H x 10”W x 5”D, with the mounting dimensions shown above.

- c. The photocell must be mounted with the sensor window pointing NORTH.
- d. There are two methods of connecting the photocell:
 - i. Mounted to the top of the enclosure
 - ii. Externally mounted

Electrical Installation Instructions

- a. It is recommended to drill two access holes on the bottom side of the enclosure, one for cables into the enclosure, and one for output cabling to the load devices. It is also recommended to use strain-relief or rubber bushings to cushion the wire from the enclosure sharp edges.
- b. Connections from the AC source power to the controller inputs are shown on the left side of the Wiring Diagram in Figure 1 and listed in Table 1 below.
- c. Connection from the Controller AC outputs to the Load are shown on the right side of the Wiring Diagram in Figure 1 and listed in Table 1.
- d. There are three terminal blocks for the Photocell wires. The Photocell black wire connects to the black terminal block, white wire to the white terminal block and the red wire to the red terminal block.

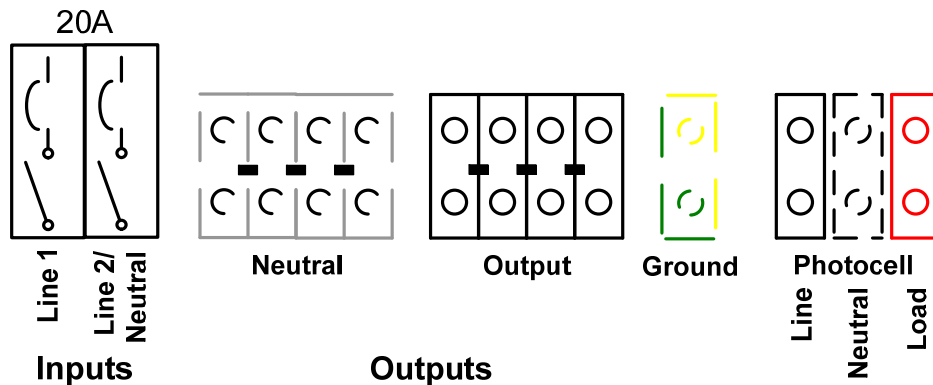

Figure 1: Customer Interface Wiring Diagram



Heliport 120VAC Controller with Photocell Installation Instructions

HL-HSC-AC1ACP

AC Input Wiring
"Line 1", 20A, 2-pole Circuit Breaker AC Line 1 Input for switching load on by photocell (120VAC).
"Line 2", 20A, 2-pole Circuit Breaker AC Line 2 Input <u>Neutral</u> (120VAC).
"Ground", Green / Yellow Terminal Block
AC Output (Load) Wiring
Black Terminal Block: AC Line 1 out to Load switched by Photocell.
The White Terminal Block is used for the load return (Line 2 <u>Neutral</u>).

Table 1: Controller Wiring Instructions

Operation with Photocell

- The photocell will switch 120VAC on at the Black Load Output Terminal Blocks when nighttime light conditions are detected by the photocell sensor.
- During daylight conditions there should be less than 10VAC at the Black Output Terminal Blocks.

Operation with Override Switch

- When the switch is placed in "Photocell" the system will be activated by the photocell.
- When the switch is placed in "Override" the system will remain on indefinitely. This position provides a manually-operated mode.

System Trouble Shooting

If your system does not operate as expected here are some suggestions to help locate the source of the problem:



Heliport 120VAC Controller with Photocell Installation Instructions

HL-HSC-AC1ACP

- a. Input Voltage Verification: With the circuit breaker in the OFF position, verify that you have 120VAC between the circuit breaker and the white (neutral) terminal blocks. If your system does not pass this test you may have a problem with your input wiring or voltage source.
- b. Photocell Operation (Disconnect load for testing): Switch the circuit breaker ON. For daytime light conditions (you may shine a bright light at the Photocell sensor but NEVER aim it directly at the Sun) the PC Control output voltage at the black terminal block should be less than 10VAC. You may simulate nighttime conditions by covering the Photocell light window with an opaque material, which should output close to 120VAC at the black PC Control terminal blocks.
- c. If your system passes steps b and c, you may have a problem with your load wiring or devices. A test 120VAC light bulb may be used for testing between one of the L1 black output terminal blocks and L2 white terminal blocks.
- d. If your system does not pass step b or c, you may have a problem with the Photocell.



Heliport 120VAC Controller with Photocell Installation Instructions

HL-HSC-AC1ACP

Replacement Parts List

You may contact Flight Light, Inc at (800) 806-3548 for replacement parts according to the following chart:

Name	Part Number
Photocell	68-6390-FAA
Relay	27-PRD-7AY0-120
20A Circuit Breaker	27-FAZ-C20/2
Lightning Arrestor	27-DS72RS-120